



# Find The Defective Capacitors, Coils, Resistors, SCRs And Triacs That All Other Testers Miss . . .

Presenting a new, improved, dynamic and mistake proof LC Analyzer that finds defective components all other testers miss.

- Dynamically tests capacitors for value from 1 pF to 20F, leakage with up to 1000 volts applied, dielectric absorption and equivalent series resistance (ESR).

- Dynamically tests inductors, in-or-out of circuit, from 1 uH to 20 Henrys for opens, shorts, value, and detects even one shorted turn.

- Dynamically tests SCRs, Triacs High Value Resistors, and locates the distance to within feet of an open or short in a transmission line for an added bonus.

- Automatically makes all of the tests, compares them to EIA (Electronic Industries Association) standards and reads the results as Good or Bad. Enter all information right from the component without look-up charts, calculations, or errors.

- Extends your testing capability to places where an AC cord won't reach, with rechargeable 9 hour battery or AC operations.

- An added feature alerts you that the fuse has opened, and that there may be residual high voltage on the component under test.

**New!**  
**And Improved!**



It's like having your own Standards Engineer with you at all times.

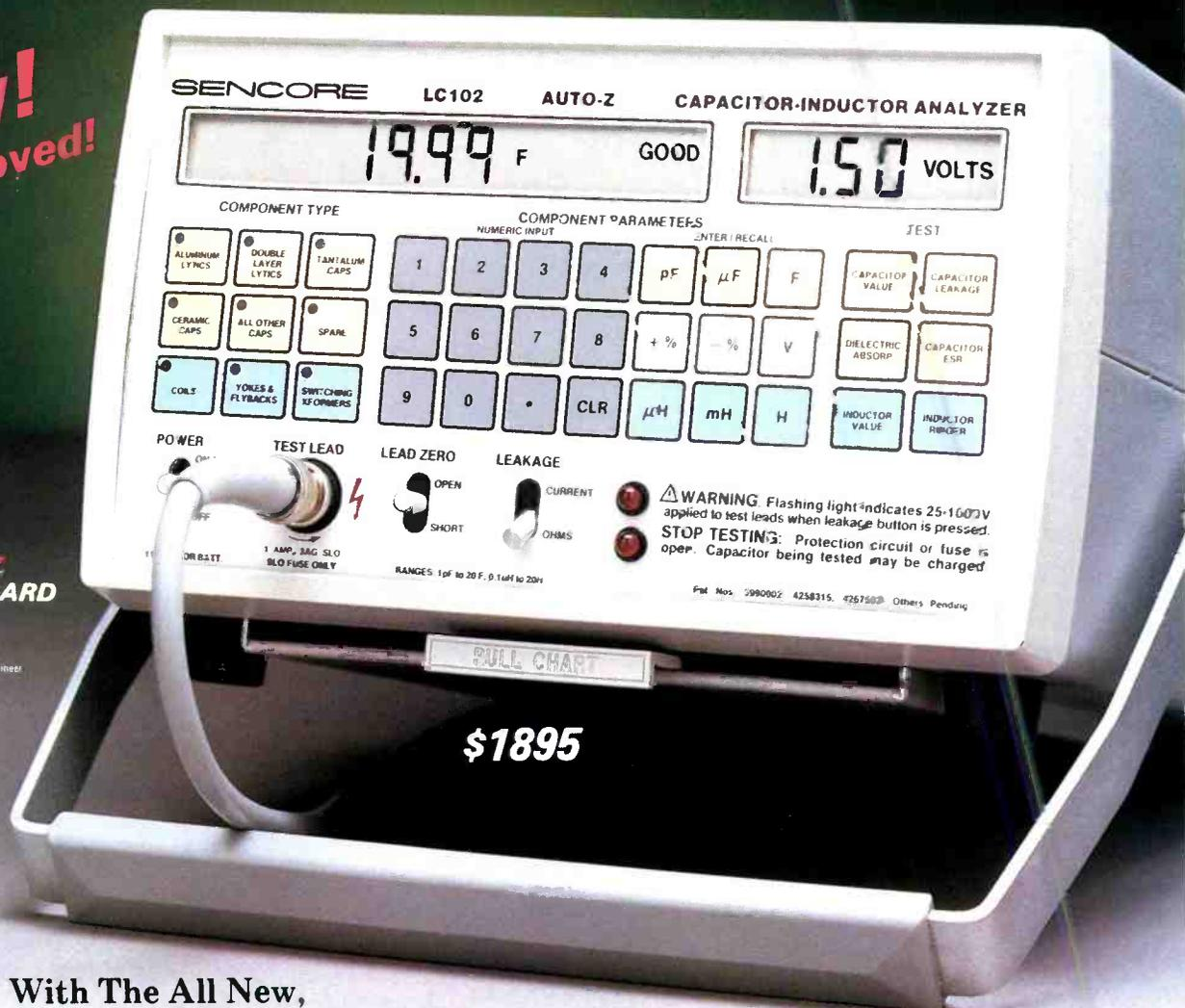

With The All New,  
LC102 AUTO-Z™ Automatic  
Capacitor-Inductor Analyzer.  
Four Patents

**Call 1-800-SENCORE**  
**In Canada Call 1-800-851-8866**

Circle (1) on Reply Card

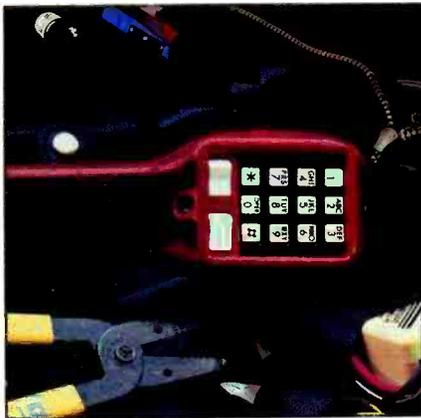

Page 6

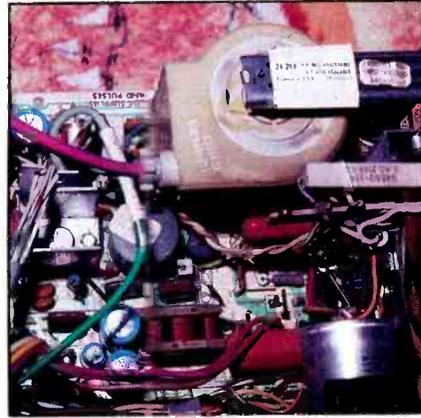

Page 12

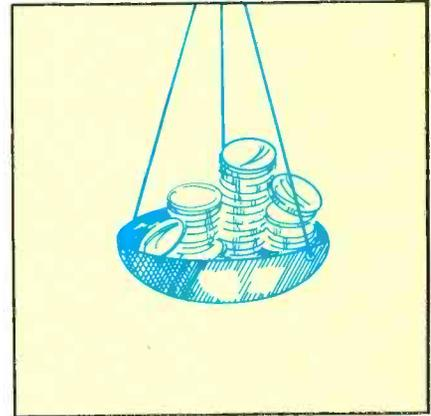

Page 50

## FEATURES

### 6 Setting up an Electronics Servicing Workbench

By Conrad Persson

If you're still using the same old tools you've been using for years, you probably don't even realize how much nicer the job would be with the right tools, kept in top shape. Whether you're setting up your first bench or improving your old one, here are some ideas for setting up a top-notch shop.

### 12 Servicing Scan-Rectified Voltage Sources

By Homer L. Davidson

One plus of scan-rectified B+ voltages in TV design is the elimination of unwanted heat from B+ dropping resistors. One minus is they are guaranteed to stop producing voltages when the horizontal deflection ceases, and when you add start-up and shut-down functions, the problem can be a bit intimidating.

### 38 Servicing Zenith Microcomputers

Part I: The Backplane

By John A. Ross

This article begins a series on servicing Zenith microcomputers. In Part I, the author introduces the

series with a detailed look at Zenith's backplane design, which interconnects all the circuitry contained on modular printed circuit boards. A close look at the backplane gives the servicer an understanding of how the circuitry works — a big help when you have to figure out why it doesn't work.

### 44 Implementing an Electrostatic Discharge Awareness Program

If you want to make the world a safer place for those poor little static-sensitive devices, take a page from the program developed by the Airborne Electronics Division at Robins Air Force Base. You might not need to be as detailed as the Air Force — they even specify the floor wax — but you'll get an idea of how big the ESD problem is for performance-critical components.

## DEPARTMENTS

### 2 Editorial

Managing Information Overload

### 4 News

### 10 Troubleshooting Tips

### 20 What Do You Know About Electronics?

Voltage Phasors

### 22 Feedback

### 24 Test Your Electronics Knowledge

### 27 Profax

### 46 Products

### 48 Symcure

### 49 Books

### 50 Business Corner

Setting a Fair Price

### 51 Literature

### 52 Audio Corner

Troubleshooting Problems in the De-emphasis Circuit — Part I

### 54 Computer Corner

IBM Personal Computer Servicing Do's and Don'ts

### 56 Video Corner

Using Logic in Troubleshooting — Part I

### 58 Readers' Exchange

### 60 Advertisers' Index

## ON THE COVER

Setting up an electronics servicing workbench requires the right tools and cleaning products, plus some extras the servicer might not think about, such as proper lighting and ventilation. Even if it doesn't save time, a well-planned workbench can make any job easier and more enjoyable. Photo courtesy of Contact East, a supplier of electronic products.

# Managing information overload

Not too long ago, I saw a show on PBS that dealt with the problems of being a pilot in the new generation of fighter aircraft. It dealt with such things as the sheer physical challenge of remaining conscious through a multi-G turn, out-maneuvering crafty enemy pilots, and many other concerns facing today's fighter pilots.

One of the most fascinating — and chilling — segments dealt with the consequences of information overload. One Vietnam War U.S. Air Force pilot with whom the show's producers talked had been shot down; he had failed to take evasive action even though his wingman had shouted at him repeatedly that there was an enemy fighter on his tail.

The pilot's eyes and ears were bombarded with information. He was watching the terrain below glide past his aircraft; in the air he watched many aircraft, both friendly and unfriendly; and he had to monitor his radar and his instruments. His earphones crackled with radio transmissions — the air controller was issuing information and instructions for all friendly aircraft in the vicinity, the surrounding aircraft were communicating to coordinate the battle. The pilot's mind was like a computer, racing to process all of this input and react to it. When the critical warning came, all of his faculties were stretched to the limit, and it didn't get through. The consequence was that the enemy had a sitting duck for a target and the plane was shot down.

Sometimes I think that in today's complex and fast-moving world, we're all a little like that pilot. We're constantly assailed by information that's important to our lives, so much so there's a serious danger we'll miss a critical piece of information. That's especially true in occupations where the pace of technological change is so fast it's almost impossible to assimilate it all, as in the case of consumer electronics servicing technicians.

Think about all of the technology developed for consumer use in the past few years: compact discs, personal computers, cellular telephones, facsimile, satellite TV, stereo TV, surface-mount components, Walkman-type products. Now there's news of high-definition TV, fiber optics and more. Is something out there shouting a warning we can't hear because of the other noise?

I don't know, but here are a few thoughts about keeping the noise at a manageable level:

- Try to separate the interesting from the truly critical. For example, there's been a lot of talk about HDTV. It will be here one day, and technicians will have to deal with it. But a standard has yet to be developed, so it will be years before anyone is called on to service an HDTV set. Keep an eye on this kind of technology, but don't let it distract you from what's here now or just around the corner.

- Once you have sorted out what's important, sort that information into what's important to you and what's important to someone else. In other words, computers, facsimile and cellular telephones are all facts of life today, and every technician should be aware of them. However, if you plan to concentrate on servicing computers, you might want to put learning about the intricacies of facsimile machines on the back burner.

- Concentrate on the technologies that affect several areas of electronics. For example, some readers might pass right over articles about ESD, but with microminiaturization as the wave of the future, ESD is real and here to stay. On the other hand, if you see an article about a technology that really doesn't interest you or affect your area of expertise, target another article.

- Don't force yourself to remember everything. Keep up your files, and if the files themselves become overwhelming, consider investing in a computer that can manage the unmanageable stack of information. And don't rely on memory to the detriment of good, basic troubleshooting skills. Remembering that diode xyz is a troublemaker in model abc TV is only helpful if it is a common problem in a common model. If you try to file away every case history on the off chance you might see that particular symptom again, you're sure to frazzle some brain circuits.

- Try to keep an open mind. One way *not* to deal with information overload is to refuse to accept any new information. If you only want to service TVs and someone brings in a VCR, stop and think about it. You won't know whether it's a potential gold mine until you at least look at the technology.

*Nile Conrad Pearson*

# LEADER

CARVER DENON harman/kardon  HITACHI  
 NEC ONKYO  PIONEER  SANSUI  
 SHARP SONY  TEAC YAMAHA

## These leaders specify Leader.

When servicing electronics, depend on Leader for your test equipment needs.

Leader meets the standards of so many, because we set such high standards in design.

Equip your bench with our standard test equipment as required by manufacturers. Leader continually consults manufacturers and their service facilities to determine what products and features you'll need. The unique features on Leader equipment help you work smarter and increase efficiency.

SEE LEADER INSTRUMENTS AT ELECTRO '89, BOOTHS 1663-1667

You'll find hard-to-beat capabilities and value throughout the Leader line.

See all there is to Leader's leadership, and benefit from our more than 34 years of experience. Phone now to discuss your equipment requirements, for a copy of our catalog, and for the name of your nearest "Select" Leader Distributor. All Leader equipment is backed by a TWO-YEAR WARRANTY, and factory service on both coasts.

Call toll-free  
**1 800 645-5104**  
 In NY State  
**516 231-6900**

Leader Instruments Corporation  
 380 Oser Avenue, Hauppauge, New York 11788  
 Regional Offices:  
 Chicago, Dallas, Los Angeles, Boston, Atlanta  
 In Canada call Omntronix Ltd. 416 828-6621

## LEADER

FOR PROFESSIONALS WHO KNOW  
 THE DIFFERENCE

- |                                       |                                 |                                       |
|---------------------------------------|---------------------------------|---------------------------------------|
| 1. LCG-400S NTSC Pattern Generator    | 7. LSW-333 TV Sweep Generator   | 11. LDM-171 Distortion Meter          |
| 2. LVS-5850B NTSC Vectorscope         | 8. LAG-126S Audio Generator     | 12. LTC-906 Transistor Checker        |
| 3. LDC-823S 250-MHz Frequency Counter | 9. LMV-185A AC Millivoltmeter   | 13. LDM-853A Digital Multimeter       |
| 4. LMS-238 TV Stereo Generator        | 10. LFM-39A Wow & Flutter Meter | 14. LPS-152 DC Power Supply           |
| 5. 3216 AM/FM Stereo Generator        |                                 | 15. LPM-8000 Laser Power Meter        |
| 6. LHM-80B High Voltage Meter         |                                 | 16. LBO-2060 CRT Readout Oscilloscope |

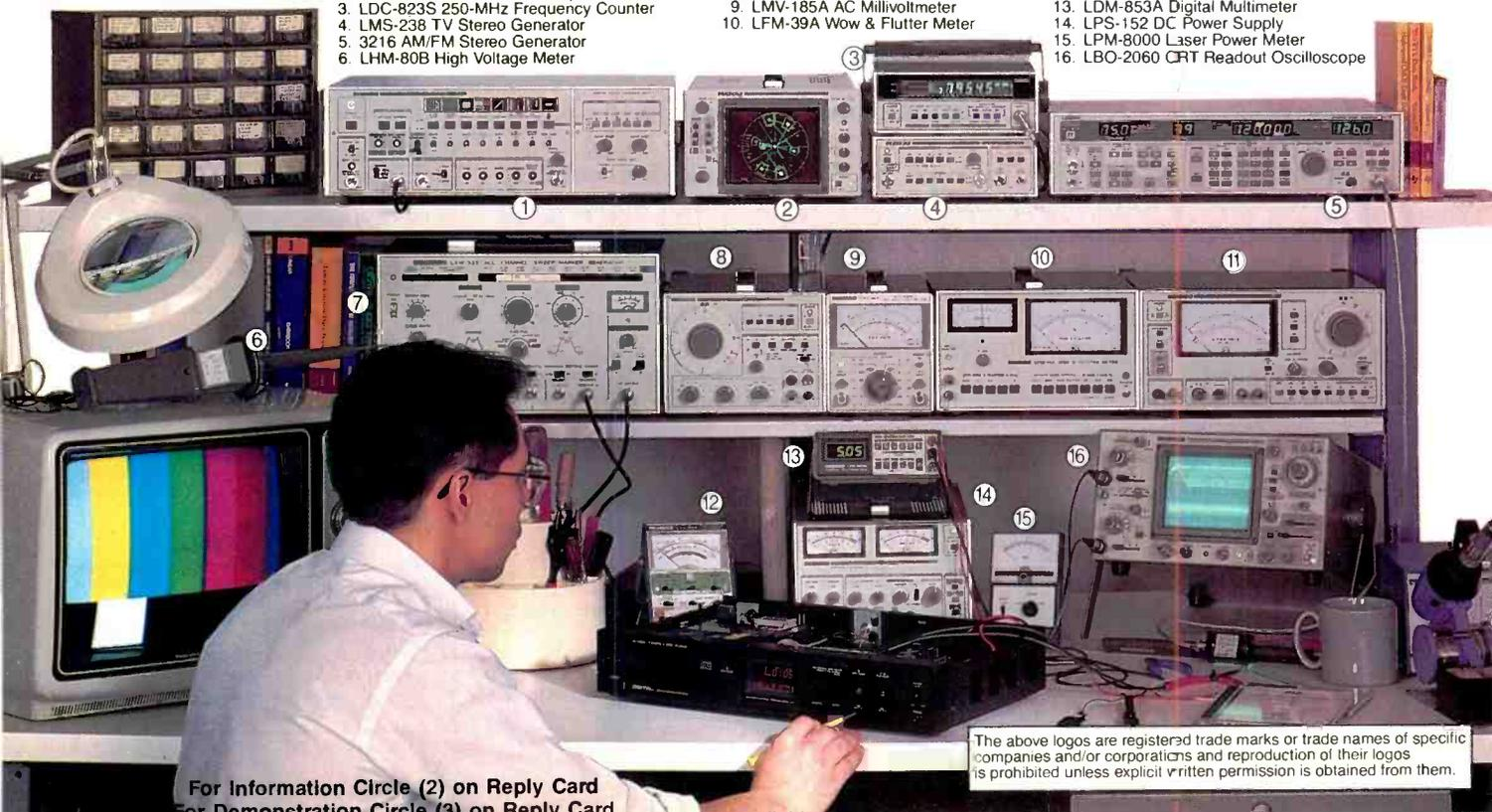

The above logos are registered trade marks or trade names of specific companies and/or corporations and reproduction of their logos is prohibited unless explicit written permission is obtained from them.

For Information Circle (2) on Reply Card  
 For Demonstration Circle (3) on Reply Card

## Survey rates service quality

Americans rate the repair service they receive higher than some recent publicity would suggest, according to studies by W.J. Lynott, Associates, a Glenside, PA, consulting company. Using what they call Customer Satisfaction Audits, the company surveys recent service customers of client companies to learn their attitudes in five key areas of customer satisfaction: quality of workmanship, promptness and dependability of the service, courtesy of the service personnel, the price charged and overall satisfaction.

The replies are converted to numeric scores in each of the five areas. A national average of all respondents is maintained so client companies may compare their scores with the average of their competition. The current national averages are (on a scale of 1 to 10): quality of workmanship, 8.33; promptness and dependability of the service, 9.28; courtesy, 9.33; price charged, 6.83; overall satisfaction, 8.03.

For a brochure with further information, write W.J. Lynott, Associates, 614 N. Easton Road., Suite 200, Glenside, PA 19038, or call 215-886-3646.

## Report analyzes future trends

Revenues from integrated optical and optoelectronic circuits will increase from \$662 million to \$1.06 billion from 1988 to 1994, according to a report published by Frost & Sullivan. "The U.S. Optoelectronics and Integrated Optics Component Market" (#A2087) analyzes optoelectronic technologies, the products and expanding product markets, industry trends and competitive strategies. Product markets examined in the study range from light- and infrared-emitting diodes, which have reached commercial maturity, to the still emerging growth areas of integrated optical and optoelectronic circuits.

According to the study, by 1994 or earlier, the market for integrated optical and optoelectronic circuits will be ready for a rapid upturn. Although the present U.S. market for optical ICs (OICs) is still small — \$8 million in 1988 — that market is expected to increase to \$56 million by 1994. Other trends forecast in the report include the following:

- The optocoupler market should grow from \$120 million in 1988 to \$190 million by 1994.

- The largest optoelectronic market, LEDs and IREDS, will grow from \$224 million in 1988 to \$353 million in 1994.
- LED display revenue will increase from \$134 million to \$169 million between 1988 to 1994.
- Diode lasers, a \$54 million market in 1988, will be a \$90 million market in 1994.
- The photodetector market will increase from \$68 million to \$112 million from 1988 to 1994.
- The photovoltaic market will expand from \$54 million in 1988 to \$88 million in 1994.

For more information on the report, contact Customer Service, Frost & Sullivan, 106 Fulton St., New York, NY 10038; 212-233-1080.

## NPEC publishes seminar schedule

The national Professional Electronics Convention seminar schedule will include sessions on VCR servicing, digital and microprocessor technology, oscilloscopes and more. The convention is scheduled for August 7-12 at the Loews Ventana Canyon Resort in Tucson, AZ. The seminar schedule includes the following sessions:

- Troubleshooting VCR system-control servos, presented by Sharp, August 7.
- Basic digital, a 2-day school presented by the Electronic Industries Association (EIA), August 8-9.
- Advanced microprocessor, a 2-day school presented by the EIA, August 11-12.
- Servicing Super VHS, presented by JVC, August 8.
- LaserVision videodisc technology, presented by Pioneer, August 8.
- Technical operation of the CEBus, presented by the EIA, August 11.
- Troubleshooting microwaves to the control-panel level, presented by Sharp, August 11.
- Camcorder servicing, presented by Hitachi, August 12.
- A scope school, featuring advanced techniques for waveform analysis in servicing high-tech consumer products, presented by Sencore, August 12.
- Service familiarization on the SVS-990 VCR with a handscanner, presented by Toshiba America, August 12.

For more information, write to NPEC '89, 2708 W. Berry St., Fort Worth, TX 76109, or call 817-921-9061. ■

The magazine for consumer electronics servicing professionals

# ELECTRONIC

Servicing & Technology

**Electronic Servicing & Technology** is edited for servicing professionals who service consumer electronics equipment. This includes service technicians, field service personnel and avid servicing enthusiasts who repair and maintain audio, video, computer and other consumer electronics equipment.

## EDITORIAL

Nils Conrad Persson, *Editor*  
 Carl Babcoke, *Consumer Servicing Consultant*  
 Tom Cook, *Senior Managing Editor*  
 Alisa Carter, *Associate Editor*  
 Andrew Naugher, *Editorial Assistant*

## CONSULTING EDITORS

Homer L. Davidson, *TV Servicing Consultant*  
 Christopher H. Fenton, *Circuit Fabrication Consultant*  
 Victor Meeldijk, *Components Consultant*  
 Kirk G. Vistain, *Audio Consultant*  
 Sam Wilson, *Electronics Theory Consultant*  
 William J. Lynott, *Business Consultant*

## ART

Kevin Callahan, *Creative Director*  
 Barbara Miles, *Graphic Designer*

## BUSINESS

Cameron Bishop, *Group Vice President*  
 Eric Jacobson, *Group Publisher*  
 Greg Garrison, *Sales Manager*  
 Marcia Durrett, *Marketing Director*  
 Evelyn Hornaday, *Promotions Manager*  
 Darren Sextro, *Promotions Coordinator*  
 Dee Unger, *Advertising Business Manager*  
 Catherine Grawe, *Advertising Coordinator*

## ADVERTISING

Greg Garrison, 913-888-4664

## ADMINISTRATION

R.J. Hancock, *President*  
 Chuck Rash, *Corporate Circulation Director*  
 Sandra Stewart, *Circulation Director*  
 Donna Schlagle, *Circulation Manager*  
 Customer Service, 913-541-6628



Member, Audit Bureau of Circulation



Member, American Business Press



Member, Electronic Servicing Dealers Association

## CORRESPONDENCE

Editorial, advertising and circulation correspondence should be addressed to: P.O. Box 12901, Overland Park, KS 66212-9981 (a suburb of Kansas City, MO); 913-888-4664. Home office fax: 913-541-6697. Home office telex: 42-4156 INTERTEC OLPK

**SUBSCRIPTION PRICES:** one year, \$19.49; two years, \$32.98 in the USA and its possessions. Foreign countries: one year, \$23.49; two years, \$36.98. Single copy price: \$2.50; back copies, \$3.00. Adjustment necessitated by subscription termination to single copy rate. Allow 6 to 8 weeks for new subscriptions.

**PHOTOCOPY RIGHTS:** Permission to photocopy for internal or personal use is granted by Intertec Publishing Corp. for libraries and others registered with Copyright Clearance Center (CCC), provided the base fee of \$2 per copy of article is paid directly to CCC, 21 Congress St., Salem, MA 01970. Special requests should be addressed to Eric Jacobson, publisher. ISSN 0278-9922 \$2.00 + 0.00

**Electronic Servicing & Technology** (ISSN 0278-9922) is published monthly for \$19.49 per year by Intertec Publishing Corp., 9221 Quivira Road, Overland Park, KS 66215. Second-class postage paid at Shawnee Mission, KS and additional mailing offices. POSTMASTER: Send address changes to ELECTRONIC SERVICING & TECHNOLOGY, P.O. Box 12960, Overland Park, KS 66212. ©1989 All rights reserved.



# FLUKE



# PHILIPS

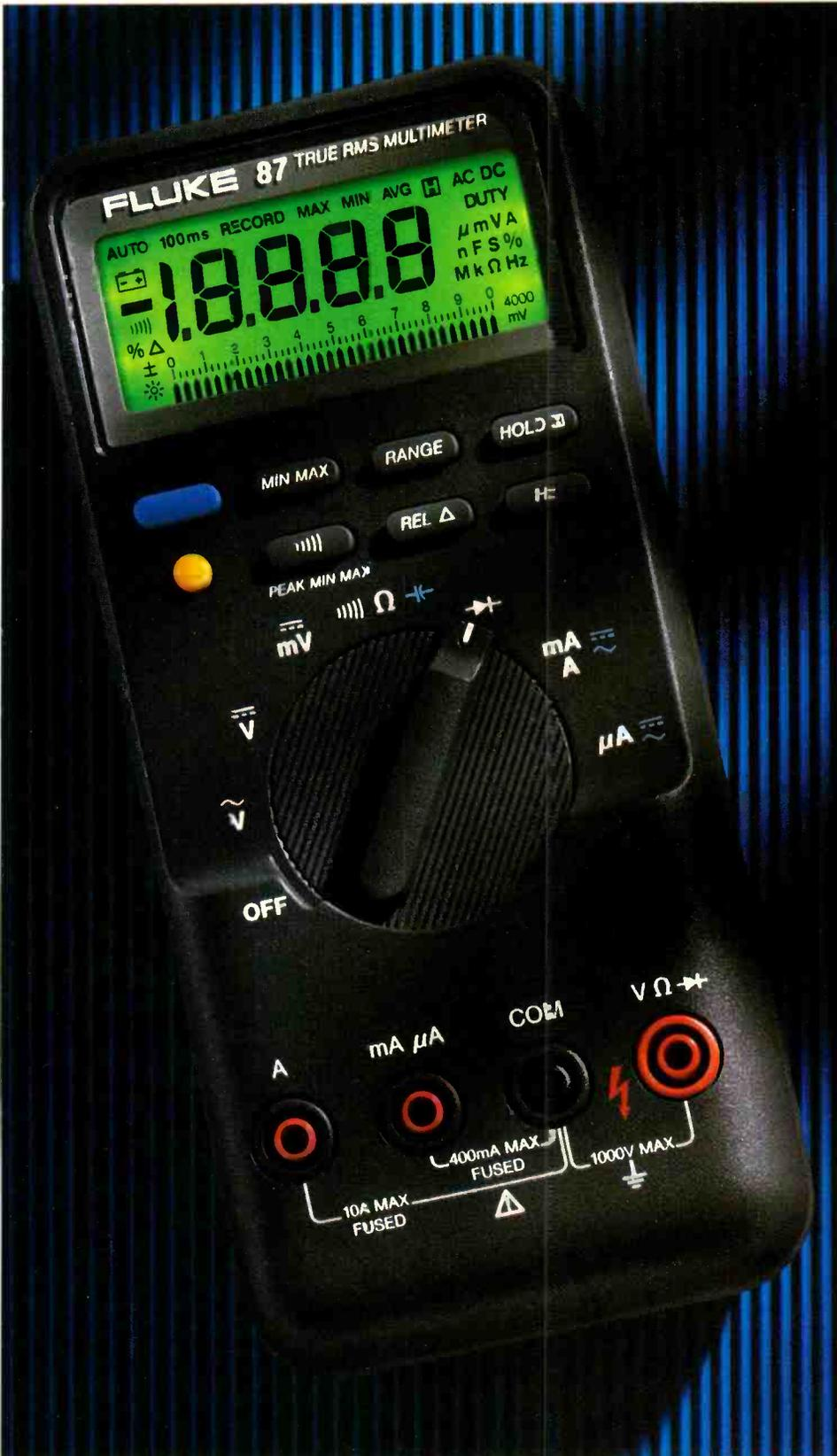

The new 80 Series is a digital meter, an analog meter, a frequency counter, a recorder, a capacitance tester, and a lot more.

It's the first multimeter that can truly be called "multi" . . . not only standard features, but special functions usually limited to dedicated instruments.

Plus, innovations only Fluke can bring you. Like duty cycle measurements. Or recording the minimum, maximum and average value of a signal. Or the audible MIN MAX Alert™ that beeps for new highs or lows.

There's even Fluke's exclusive Input Alert™, that warns you of incorrect input connections. And a unique Flex-Stand™ and protective holster, so you can use the 80 Series almost anywhere.

Make sure your next multimeter is truly multi. Call today at 1-800-44-FLUKE, ext 33.

FROM THE WORLD LEADER IN DIGITAL MULTIMETERS.



FLUKE 83	FLUKE 85	FLUKE 87
\$189*	\$219*	\$259*
0.3% basic dc accuracy	0.1% basic dc accuracy	0.1% basic dc accuracy
5 kHz acV	20 kHz acV	20 kHz acV
Analog bargraph & zoom	Analog bargraph & zoom	High resolution analog pointer
Three year warranty	Three year warranty	True rms ac
		1 ms PEAK MIN MAX
		4½ digit mode
		Back lit display
		Three year warranty

\*Suggested U.S. list price

Circle (4) on Reply Card

# FLUKE

The new Fluke 80 Series shown actual size

John Fluke Mfg. Co., Inc., P.O. Box C9090 M/S 250C, Everett, WA 98206  
 U.S. 206-358-5400 CANADA 416-890-7600 OTHER COUNTRIES 206-358-5500  
 © Copyright 1988 John Fluke Mfg. Co., Inc. All rights reserved. Ad No. 0581-F80

# Setting up an electronics servicing workbench

By Conrad Persson

Today, with technology changing almost continuously, it takes almost a constant effort to remain aware of the current technologies and to be equipped to diagnose and service them.

Given the rapid pace of technological advance today, it might not be a bad idea to look at the tools, test equipment and accessories on your workbench as often as once a year to see if it's time to add or replace something. Of course, many of the old tools and test equipment still perform the function they were designed to do, but much of the new technology

either hand wired or based on printed-circuit boards with wide traces, the type of lighting available at the service bench wasn't really critical. Today, with vanishingly thin circuit traces and tiny, surface-mounted components, it's difficult to see the smallest connections even at noon in full sun. Given the ambient lighting available at many electronics service benches, it's a wonder that the technician can see well enough to find the test points to probe, or to remove and replace components.

With today's tiny circuits, if techni-

cient. It is electrostatic discharge (ESD), and today it is a common cause of failures in consumer electronics products. Take a look at the schematic diagram of any of today's sophisticated electronics products found in the home: TV, CD player, VCR, microwave oven. Have you seen one lately that doesn't feature at least one IC?

Not every IC is static-sensitive, but many of them are. As discussed in the article "Implementing An Electrostatic Discharge Awareness Program" (see page 44 of this issue), in many cases it doesn't take much to damage or destroy some of these components. The voltage threshold at which a human can detect an electrostatic discharge is around 4,000V. Some sensitive components will be damaged by discharges in the range of one-tenth of this magnitude. It should be clear, then, that the presence or absence of crackling discharges is no guide as to whether ESD protection is required.

The answer to this problem is clear and compelling: Every consumer electronics product, every circuit board and every component should be treated as if it's susceptible to ESD damage. Every bench position and every tool kit for servicing consumer electronics products should be equipped with antistatic wrist straps and antistatic mats. Plastic materials such as styrene-foam cups and cigarette, cookie and cracker wrappers, which are capable of generating and holding a static-electric charge, should be banished from the work bench. Every technician should be instructed in the use of antistatic products and in the importance of keeping static-generating products away from electronics that are opened up for servicing.

## Test equipment

It's probably possible to still get by in electronics servicing with a simple DMM, a 20MHz scope and a few other

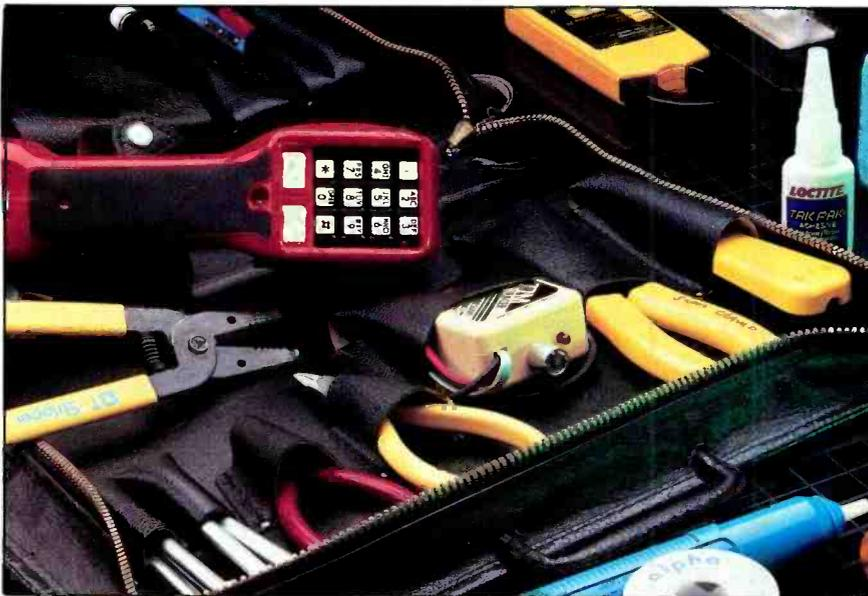

requires more sophisticated servicing equipment, and there is now a requirement for more ancillary equipment than ever before.

## Lighting and other visual equipment

Back in the good old days, when most consumer electronics products were

either hand wired or based on printed-circuit boards with wide traces, the type of lighting available at the service bench wasn't really critical. Today, with vanishingly thin circuit traces and tiny, surface-mounted components, it's difficult to see the smallest connections even at noon in full sun. Given the ambient lighting available at many electronics service benches, it's a wonder that the technician can see well enough to find the test points to probe, or to remove and replace components.

## ESD protection

You can't see it, you can't smell it, you can't taste it, and you often can't feel it, but it's lurking in every servicing facility, just waiting for an opportunity to damage or destroy a sensitive compo-

Persson is editor of *ES&T*.

simple pieces of test equipment. However, today's sophisticated consumer electronics products almost cry out for sophisticated tools and test equipment to service them. For example, in his book "Troubleshooting and Repairing Compact Disc Players," published by Tab Books, Homer Davidson recommends the following list of test products if you want to service compact disc players:

- a dual-trace oscilloscope
- an optical power meter
- a digital multimeter
- a low-frequency AF oscillator
- a signal generator
- a capacitance meter
- a frequency counter
- test discs
- special tools, filter adjustment circuits, manufacturers' special jigs, a wrist strap, etc.

The same is true with VCR repair. Take a look at any VCR servicing manual. If you want to get serious about servicing them, you might consider purchasing from a list of test gear like this one from a Quasar VCR service manual:

- a VHS alignment tape
- a tape back-tension meter
- a reel table-height fixture
- a dial torque gauge
- a tension-post adjusting plate
- a post adjustment plate
- a retaining ring remover
- an H-position adjustment fixture
- a fine adjustment screwdriver
- a post adjustment screwdriver
- a V-hold adjustment tool
- a lock screw wrench

If your preference runs to servicing computers, here's another list: a disk drive exerciser, logic probes and pulsers, logic test clips and a lot more.

In addition to the test equipment, there are such things as diagnostic disks that can make servicing computers and peripherals much easier and faster.

### Cleaning supplies and other chemicals

These days, many consumer electronics products, such as VCRs and camcorders, are actually electromechanical devices. You also have computer floppy disk drives with moving parts that wear and break, and sensing heads and other mechanical components that are subjected to wear and travel of the magnetic medium. As a result, many service calls require little more than thorough cleaning of the heads or other parts of the tape path.

This kind of service requires the right kinds of supplies and techniques, which should be readily available at the bench or in the portable tool kit. For example, if you will be servicing VCRs, you will want to have available the right kind of cleaning aids and appropriate cleaning liquids such as isopropyl alcohol or Freon TF. You don't want to clean a VCR with cloth, cotton swabs or any other kind of material that might leave lint or any other kind of residue. The two materials generally recognized as appropriate for cleaning VCR heads and tape paths are chamois and plastic foam. Both of these materials are available in sticks or swabs, onto which you spray the cleaning liquid, then carefully wipe the heads and transport parts clean.

There are also cleaning tapes for VCRs and cleaning disks for computer disk drives. From the information available, it appears that most cleaning disks for computer disk drives are safe to use. In the case of VCR cleaning tapes, we used to say forget them. However, there are now at least one or two (and possibly more) that seem to be garnering a reputation for being safe and effective. Choose among these products careful-

ly. Some of them are thought to induce the very problems they are supposed to eliminate.

### Microfiche readers

Servicing technicians who rely entirely on paper servicing documentation are finding that they are using huge volumes of room just to house the filing cabinets that hold the manufacturers' servicing literature and Sams Photofact folders. However, most manufacturers now offer their service literature on microfiche. Storing microfiche takes up far less

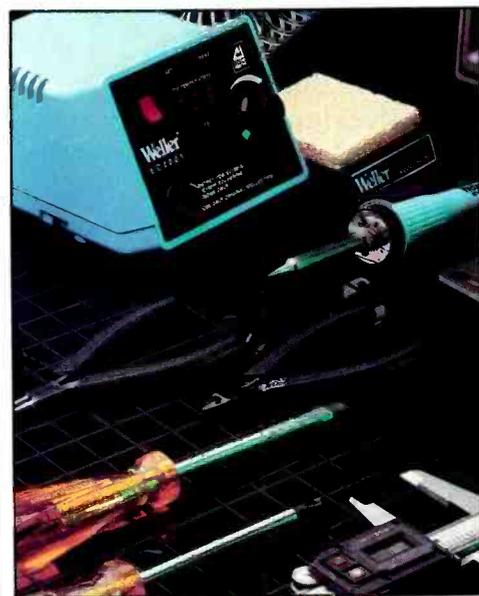

room than does storing paper manuals and schematics.

There has been some objection in the past to the use of microfiche, but some servicers who have converted to microfiche wouldn't do otherwise. One of the objections has been the cost of the microfiche reader. Yes, they cost as much as a few hundred dollars, but the small storage space for microfiche



# REPRINTS

Interested in ordering article reprints out of this or another issue? \* Reprints can be excellent learning tools for your technical staff and great marketing tools for your sales staff. Call or write Kelly Hawthorne at Intertec Publishing Corp., P.O. Box 12901, Overland Park, KS 66212; (913) 888-4664.

\*Minimum order 500 copies.



## Equipment for a well-stocked workbench

### ESD protection:

- Wrist strap
- Antistatic mat
- Antistatic holders

### Lighting

### Magnifying lens

### Test equipment and accessories:

- ac leakage tester
- Multimeter
- Oscilloscope
- Vectorscope
- High-voltage probe
- Logic analyzer
- Disk-drive exerciser
- Video-camera light box
- Test-lead kits
- Digital probes/pulsers
- Current tracers
- Logic test clips
- Break-out box
- VCR test devices: tape-tension gauge, spindle gauge
- Computer diagnostic software
- Distortion analyzer
- Frequency counter
- Function generator
- Gauges
- Field-strength meter
- Signal-level meter
- Microwave leakage tester
- Semiconductor tester
- Spectrum analyzer

### Tools:

- Screwdrivers

### Pliers

- Wrenches/nutdrivers
- Wire cutters
- Wire strippers
- Crimping tools
- Drill/reamer
- Computer keycap puller

### Accessories/miscellaneous:

- Isolation transformer
- Variable voltage transformer
- Holding fixtures/vises
- Ventilation system
- Microfiche viewer
- Vacuum cleaner
- Inspection mirrors
- CRT testers/restorers

### Soldering tools:

- Soldering iron/station
- Solder
- Flux
- Desoldering tools: Solder sucker, etc.
- Desoldering braid
- IC insertion/extraction tools
- Printed circuit track repair kits

### Chemicals/cleaning supplies:

- Coolant spray
- Tuner/control cleaner
- Video/audio head-cleaning solvents
- Computer disk-drive head-cleaning disks
- Lint-free swabs
- Screen cleaning wipes

eliminates the necessity of purchasing several filing cabinets at \$100 to \$200 each, so the overall result is a smaller, not larger, investment.

### Ventilation products

Every day, research is finding that the human system is more susceptible than anyone realized to the deleterious effects of all kinds of chemicals used in manufacturing and servicing. The average servicing facility uses a host of these chemicals: solder that generates objectionable smoke when it's applied, cleaning solvents, coolant sprays, resins and more. If a service shop can't afford to provide fume hoods to vent these fumes directly to the outdoors, it might

make sense to at least provide fans to keep these vapors from collecting in locations where the air is stagnant.

### Keeping up with the changes

The workplace continues to become a scene of increased sophistication. Manufacturing plants are now bristling with robots, automatic machinery and sophisticated control systems. Offices abound with computers and other sophisticated products to make workers more productive. Servicing has changed just as much as manufacturing facilities and offices, and it's important for servicing technicians to have at their disposal the latest equipment to get the job done safely and efficiently. ■

# New Smart Scope makes troubleshooting trouble-free.

When you're looking for trouble, the new 100 MHz Tek 2247A will help you find it—fast.

With its integrated counter/timer, Auto Setup, unique Smart-Cursors™ and voltmeter, the 2247A makes short work of the measurements you need most.

*The built-in counter/timer/voltmeter automatically calculates and displays more than 11 different voltage and time measurements.*

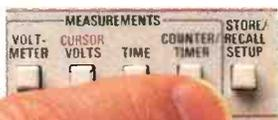

Setup, unique Smart-Cursors™ and voltmeter, the 2247A makes short work of the measurements you need most.

**Time-saving automation and ease of use** are built into every measurement routine.

The 2247A gives you one-button setup, storage and recall of up to 20 setups, time and voltage cursors, plus on-screen readouts. It also measures rise/fall time and propagation delay automatically, with counter accuracy to 0.001%.

**Best of all is the price: only \$2795!** This is the most extensive set of capabilities ever

assembled in a low-cost scope. And it's backed by Tek's standard 3-year warranty on parts and labor—including the CRT.

Bandwidth	100 MHz
No. of channels	4
Vertical/Horizontal Accuracy	2%
Integrated Counter/Timer/Voltmeter	Yes
TV Line and TV Field Triggering	Yes
Auto Setup	Yes
Store/Recall	20 front-panel setups
SmartCursors™	Yes
Warranty	3 years, incl. CRT

LISTED

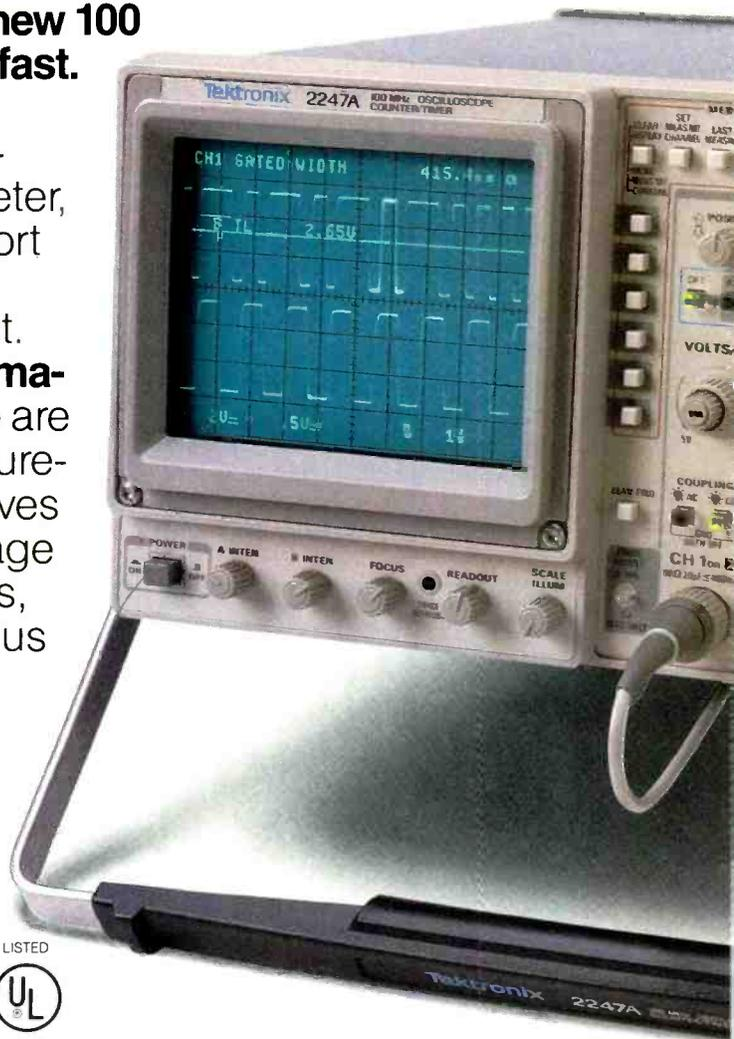

**Getting one is easy, too.**

For rapid ordering or a free videotape demonstration, call Tek today.

**1-800-426-2200**



**Tektronix®**  
COMMITTED TO EXCELLENCE

# Troubleshooting Tips

**Symptom:** Rapidly flashing screen, sound fluctuation.

**Set ID:** RCA CTC 108A

**Sams Photofact:** 1937-3

Just when you think you've seen every kind of strange problem, along comes one that's different from anything you've ever run into.

This situation occurred for me with an RCA CTC 108A. The sight and sound coming from this TV were so weird they were intimidating. By instinct, I immediately pulled the plug. After a scratch or two of the skull, I turned the set back on for a short time to try to determine just what it was I was looking at.

The flashing of the screen was so rapid I couldn't decide whether it was high voltage, which would also affect the 26V scan-derived sound supply, or video information flickering on and off.

Using the high-voltage probe at the CRT anode showed a steady 24kV. Col-

lector voltage at Q412 horizontal output transistor was a solid 119V as per spec on Photofact 1937, folder 3. This measurement ruled out problems with either the high or the low voltage.

I turned the set on and off for short periods of time to observe the symptom while minimizing the possibility of causing any damage. I noted that the LED channel display did not always display a numeral.

I pulled the IF cable link out of the tuner. As I expected, the sound and video signal disappeared, but also — a bonus — the fluctuating screen was gone. The TV displayed a solid raster.

I injected a video signal with 4.5MHz sound carrier at the IF link cable. The result was a good pattern on screen with a steady 4.5MHz sound tone. Without a doubt, the problem was in the tuner.

A good number of technicians would be intimidated with one of these all-electronic tuners in general use today and would simply put away the

schematic, remove the tuner and send it away for repair. This method is not always prudent because it will delay the repair, and you'll be left with another set cluttering up the place.

I don't advocate getting out the diddle stick and adjusting everything in sight. With the present solid-state design and its low operating voltages, factory adjustments in the critical areas generally remain stable for years. The fault usually will be a defective component (generally an IC or capacitor), or it might be one of a surprisingly large number of cold solder joints and defective cable connections. The longer a given set has been in service, the greater is the likelihood of such a defect showing up.

Some of these electronic tuners, such as the Zenith 175-5101 microprocessor remote, are certainly intimidating with their maze of connecting cables. In contrast, this RCA tuner, consisting of two modules, MSC 006A and MST 005A,

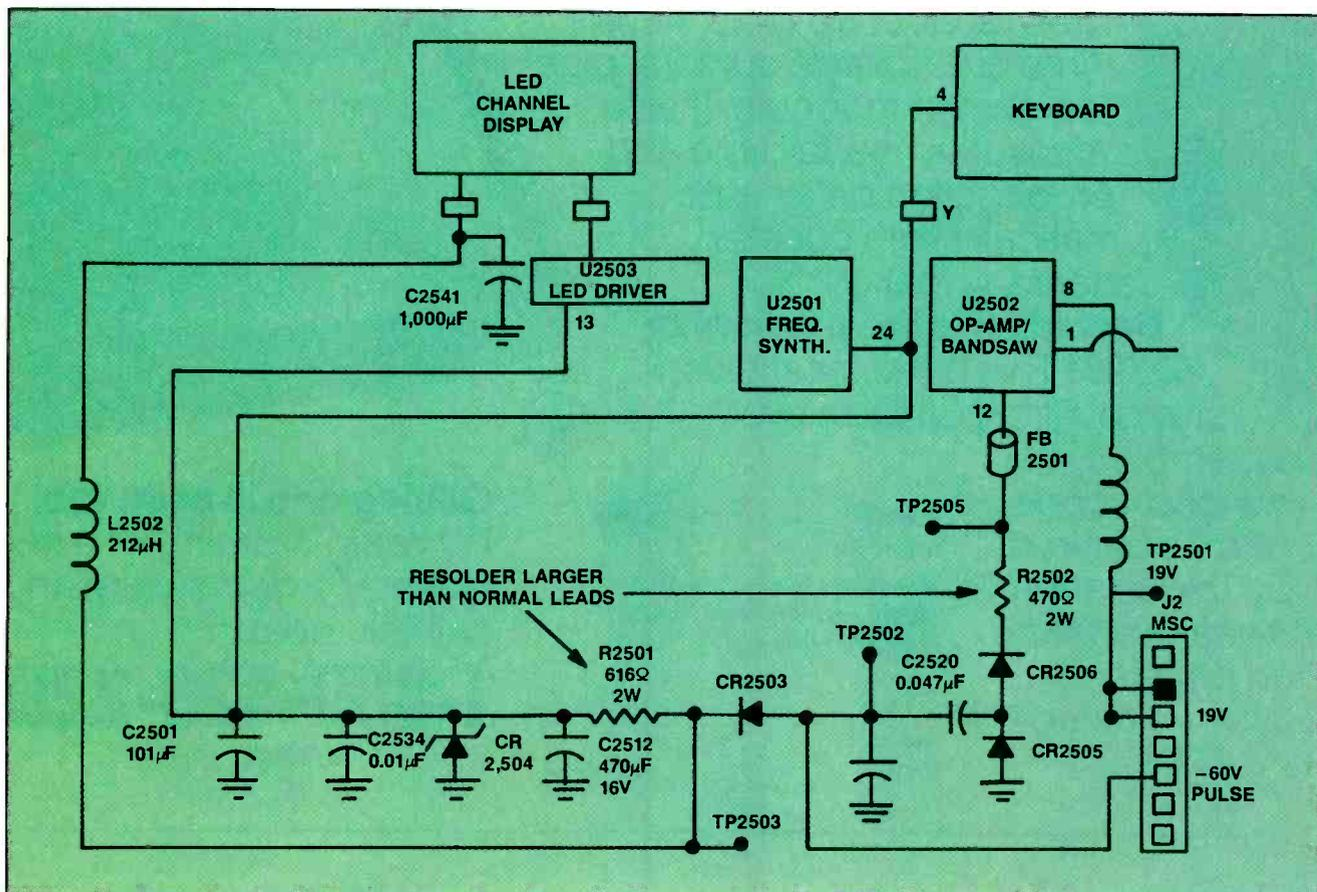

**Figure 1.** The symptoms with this RCA CTC 108A were a rapidly flashing screen and fluctuating sound. When no other leads panned out, the servicer finally looked for a cold solder joint in R2501 and R2502, the only components with larger-than-normal leads.

is a honey to service.

The two modules, held together by a few screws and a minimum of connecting cables, separate nicely and can be serviced without any additional extension cables. Limited repairs can be undertaken by merely following the same common-sense approach used daily on any digital equipment.

The approach here was to trace the symptom most apparent and easiest to follow on the schematic. The channel display was intermittent, so it stands to reason that the same intermittent was also causing the video signal to fluctuate.

The schematic for module MSC 006A showed that the display panel was powered by the 8.7V supply derived from -60V pulses at plug J2-MSC5, rectified by CR2503 and filtered by 470 $\mu$ F C2509. Voltages were as follows: test point 2504, 5.1V (OK); test point 2505, 28V (OK); test point 2501, 19V (OK).

Test point 2503 read 6.4V. This measurement didn't appear to be low enough to cause complete outage of the display, but because the 8.7V source fed only the display, I opened the circuit at L2502 to see if the display panel was loading down the circuit. This action had no effect. I checked C2509 for leakage. It was normal. A logic probe at point Y indicated a logic low for the keyboard master-slave with any button depressed. Everything seemed to be correct.

Looking at the schematic, I decided to take some advice from way back: "When everything seems to check OK but nothing is working right, eyeball the components with the larger-than-normal leads." Only two components fit that description in this portion of the TV circuitry: R2501, a 6.6 $\Omega$ , 2W resistor; and R2502, a 470 $\Omega$ , 2W resistor. I didn't bother to check the values on these two resistors because TP2504 and TP2505 were upstream and the voltages at these test points were OK.

I inspected the solder joints on these two resistors under a magnifying glass, and they appeared to be fine. Nevertheless, I heated up the soldering iron and resoldered both ends of each resistor.

Once I had finished resoldering, I turned the set on and immediately two things happened: A perfect picture appeared on screen, and a big grin appeared on my face. The channel display was a nice, bright numeral 2 and the sound was fine.

In retrospect, because I resoldered both resistors at the same time, the question arises — which of the two had the cold solder joint that caused the problem? R502 is the voltage source for the tuning control voltage, but no doubt it was R2501, the supply going to the keyboard, U2501 (the frequency synthesis IC), and U2503 (the LED channel display driver IC).

**Frank P. Stoklosa**  
Southgate, MI

# KISS YOUR AIR COMPRESSOR GOOD-BYE!

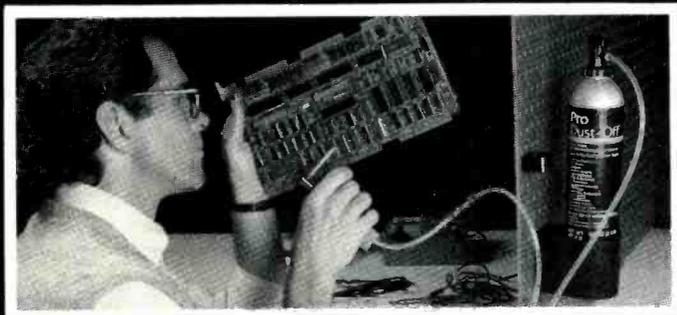

**DUST-OFF® PRO SYSTEM—THE ONE OF A KIND SYSTEM THAT DELIVERS THOUSANDS OF BLASTS AND TAKES TO THE ROAD!**

- Blows away dust, dirt and other contaminants of the electronics world with safe, dry, triple-filtered blasting power you can control—from a gentle puff to a full blast!
- Unique, sure-shot dusting gun at the end of the Pro System's flexible 8 foot hose permits easy, single-handed operation at any angle—even inverted!
- Pro Dust-Off's industrial-size, replaceable 32 oz. canister travels easily from its wall-mounted or countertop bracket in the shop to any service location!

Welcome the Dust-Off Pro System into your shop and kiss your compressed air good-bye! Available through Jensen Tool or contact the Falcon Sales Department.

**FALCON®**

Falcon Safety Products, Inc.  
25 Chubb Way, P.O. Box 1299  
Somerville, NJ 08876-1299  
(201) 707-4900 • FAX (201) 707-8855

Circle (6) on Reply Card

# Servicing scan-rectified voltage sources

By Homer L. Davidson

*A built-in fault of all scan-rectified B+ sources is the certainty that they will stop producing voltages anytime the horizontal deflection ceases. Also, when start-up and shut-down functions are added, the circuit operations become highly interactive and complicated. We recommend that you study these problems step-by-step in articles such as this where nine different circuits are examined.*

**D**uring the past 10 years, most TV manufacturers have obtained some or all low B+ voltages from circuits that rectify horizontal pulses (not 60Hz sine

Davidson is the TV servicing consultant for ES&T.

waves as in the past) usually taken from windings of the flyback transformers. Small transistors require low-voltage B+ supplies, and these various voltages are produced by rectification of the pulses from several windings having different numbers of turns. This method eliminates the unwanted heat otherwise emitted by B+ dropping resistors. Defects and repairs of typical low-voltage B+ sources will be discussed in this article.

## Preliminary troubleshooting

A dc-voltage supply can develop one or more defects internally, or defects can occur in a circuit that draws current from a dcV supply. Either condition

usually reduces the dc-output voltage from that supply. Therefore, for the first troubleshooting steps, we should determine whether the problem originates in the voltage supply or in its loads.

Sometimes the picture or sound quality can point to a defect in the video, chroma, vertical or sound circuits. In these cases, measure the B+ voltages that feed the circuit.

Some defects produce a black screen, perhaps from a loss of high voltage. However, many defects are not in the horizontal-deflection system even when the high voltage is missing. In those cases, it might be necessary to find out whether the receiver is in shut-down. If it is in shut-down, the next step is determining whether the shut-down is caused by excessive high voltage. When the high voltage is not excessive, the search brings us to the low-voltage sources. Excessive load on a source can produce shut-down because of the resulting heavy load on the flyback system and the horizontal-output transistor.

Alternatively, an overload on a low-voltage source might stop or degrade the performance of one signal circuit because the B+ voltage was too low, but it might not cause shut-down or stop the horizontal deflection. This localizes the problem.

Remember, as stated in previous articles, deflection-derived B+ voltage supplies depend on normal horizontal-deflection operation. However, with many solid-state models, horizontal deflection cannot function until the horizontal oscillator and driver stages have B+ dc voltage. Unfortunately, the low-voltage supplies cannot have voltage without normal deflection, so the oscillator and driver remain dead. To break the impasse, a start-up circuit supplies B+ voltages to oscillator and driver for a brief time after ac power is

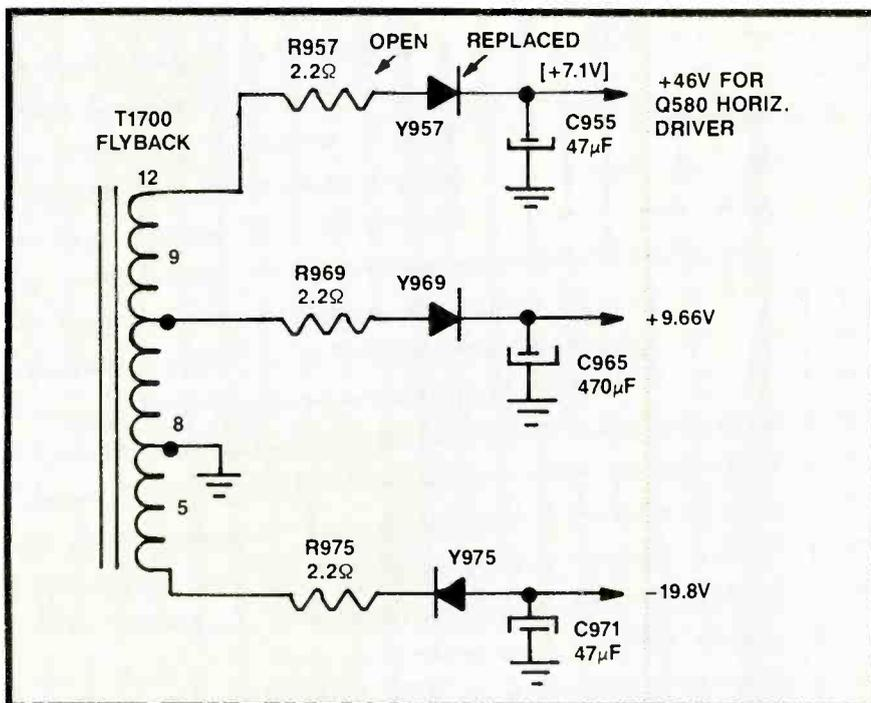

**Figure 1.** A Truetone model CNR4019B was missing both high voltage and sound. R957 tested nearly open, thus reducing the +46V to +7.1V. R957 was replaced along with diode Y957 on the suspicion that it previously had caused the overload that ruined R957. Other deflection-powered supplies were not affected.

## Multiple and interconnected low-voltages

Although the RCA CTCIII low-voltage power supplies appear very complicated, they are not when taken separately. The key to understanding these first five dcV supplies is CR107, which produces the workhorse +25.1V source and the two others derived from it. CR107 conducts to ground only the most negative parts of the pin-13 pulse/scan waveform from the T402 flyback. After the waveform's negative parts are connected to ground by CR107's conduction, the remainder of the waveform (including the signal at pin 11, which is the supply's voltage-output terminal) is totally positive and ready for filtering by C119. (Remember, CR107 operates in the scan-rectification mode. Therefore, the dc output voltage is lower than if the polarity of the signal were to be inverted.) This rectification of the signal's negative peaks is an inversion of the usual circuit as shown previously in Figure 1, where the diode conducts only during the most positive peaks of the input waveform. (By the way, both circuits are different forms of clamping.)

A capacitance-input voltage doubler is formed by C124, CR112 and CR105. In most circuits, CR112 would return to ground, but here it returns to the +25.1V supply, thus increasing the doubler's output dc voltage by +25.1V. Without the inverted supply's +25.1V, the doubler's +211V output voltage would be reduced to +186V.

Coupling capacitor C123, diode CR109 and diode CR110 compose the second

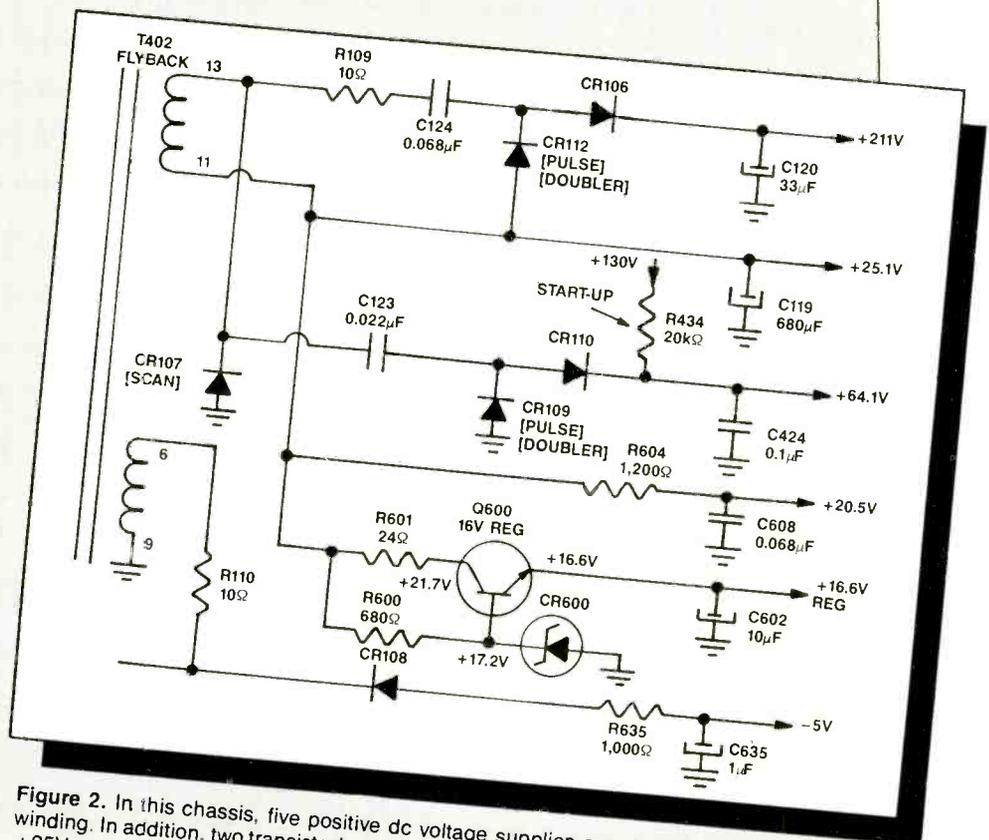

Figure 2. In this chassis, five positive dc voltage supplies are obtained from one flyback winding. In addition, two transistor/zener regulators operate with power from the work-horse +25V supply. Another flyback winding, diode CR108 and a 1 $\mu$ F filter capacitor supply 5V to several circuits. From this one flyback winding come two voltage doublers.

voltage-doubler circuit. It is similar to the other doubler except the coupling capacitance is smaller and CR109 returns to ground, not to the +25.1V source. For these two reasons, the second doubler's dc output of only +64V is lower than the first doubler's output.

The remainder of the schematic is conventional, with the +20.5V source com-

ing from the +25.1V source via R604. Also, the +16.5V source comes from the +25.1V source except through a regulator using series-pass Q600, which has its output voltage determined by zener CR600.

For the 5V source, the circuit is simple and conventional. Notice the polarity of diode CR108 for producing negative dc voltage.

first applied. This voltage kick-starts the oscillator and driver functions that trigger horizontal deflection, thus providing high voltage and the low-voltage B+ sources that power the oscillator and driver for continuous normal operation.

The following case histories show typical circuits and problems.

#### No high voltage, no sound

Symptoms of no high voltage and no sound were noticed in a Truetone model GEC4019B-08 portable color TV. Voltage tests showed higher than normal dc voltage at the horizontal-output transistor's collector, but no dc voltage at the

**Remember that defective components in low-voltage, horizontal-derived B+ supplies can cause a multitude of different symptoms. Unless the problem's location is unmistakable, first perform quick tests on the low-voltage supplies.**

driver transistor's collector. (See Figure 1.) The path of the driver's collector voltage was checked back to the +46V supply produced from flyback power. Although normal voltage should have been +46V, only +7.1V was measured at C955. Diode Y957 tested OK, but because the open in R957 indicated a previous overload, I replaced both. This solved the no-HV/no-sound problem.

#### Multiple voltage sources

One example of multiple and interconnected low-voltages is the RCA CTCIII color chassis. (See Figure 2.) Five positive dc voltage supplies are obtained from one flyback winding. In addition, two transistor/zenner regulators operate with power from the work-horse +25V supply. Another flyback winding, diode CR108 and a 1 $\mu$ F filter capacitor supply 5V to several circuits.

From this one flyback winding come two voltage doublers. This type of circuit configuration is a rarity. Also, the essential +25V supply is produced in a circuit that is inverted from the usual practice. If you follow step by step, all these functions should be clear.

With power supplies that rectify horizontal-deflection power, the supply's dc-voltage polarity is determined only

by the rectifying diode's polarity. Voltage from a diode's cathode is positive, but from the anode, the voltage is negative. However, the amount of dc voltage is determined by the pulse/scan polarity. For example, rectification of the sweep waveform's pulse provides far more voltage than rectification from an inverted pulse waveform. This latter is called *scan rectification*, or rectification of mostly the baseline between pulses. For example, scan rectification via CR107 and C119 yields the +25V source, and the higher-voltage +211V and +64.1V supplies are powered from pulse rectification. See Figure 2 in the accompanying sidebar for more information about these supplies.

Leaky or shorted diodes, such as CR106, CR112, CR107, CR109, CR110 or CR108, cause a severe power-supply overload that can produce shut-down. Of course, a near short in a component that is supplied by a dc-voltage source can also cause shut-down. Open or burned current-limiting resistors, such as R109, R110 or R601, might reduce or eliminate the output of the supply of which they are a part. Open or reduced-capacitance electrolytic-filter capacitors can reduce a supply's dc voltage. A shorted voltage-regulator transistor might increase that supply voltage; a leaky regulator transistor can cause poor regulation of the supply.

#### Shut-down

Shut-down that is delayed a few sec-

onds is usually caused by a shorted diode or filter capacitor or by excessive current drain in a low-voltage supply. Sometimes this situation is called *chassis shut-down*. By comparison, overloads from a flyback with shorted turns or a shorted horizontal-output transistor usually produce shut-down immediately. This distinction in symptoms can help you find the problem more quickly.

In many RCA color chassis that have an integrated high-voltage transformer (IHVT), the IHVT flyback can be tested quickly by using an isolated-type variable-ac transformer to supply the ac power. Prepare by shorting across 2.5 $\mu$ F C113 and connecting a jumper wire or test lead between gate and cathode of SCR100, the +130V regulator. Then connect a meter to the horizontal-output transistor's collector (case) and, by using the variable-ac transformer, increase the line voltage from zero up to whatever applies about +80V to the output transistor's collector. Scope the collector. A normal but lower-amplitude waveform hints at a +130V regulator problem. Excessive ringing or smaller pulses between the correct horizontal-frequency pulses might indicate a severe overload or shorted turns in a IHVT winding. Erratic noise spikes mixed with the normal pulses might show arcing of the internal HV diodes. If either ringing or noise spikes are viewed on the scope, replace the IHVT flyback.

If the output transistor's collector con-

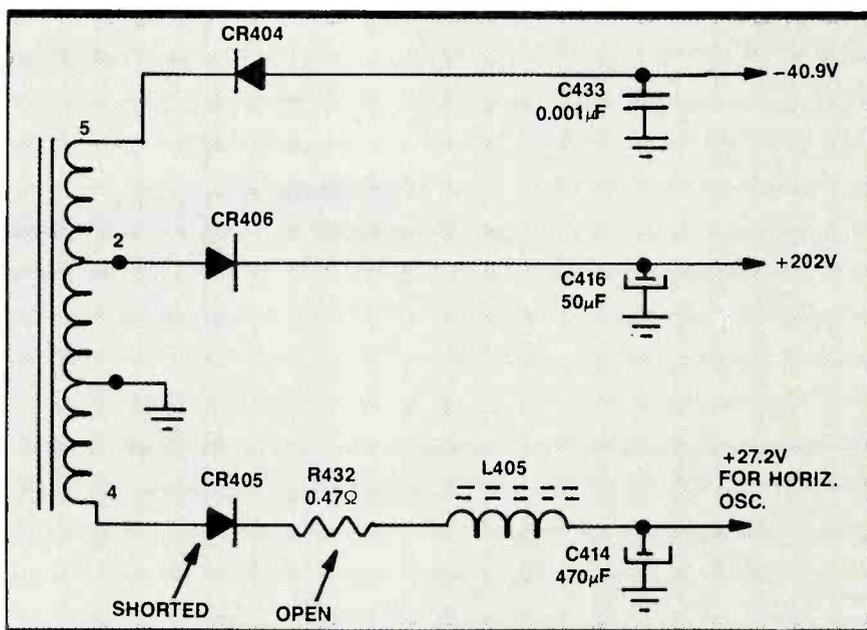

**Figure 3.** One of the most common power-supply defects caused shut-down in an RCA CTC92. Diode CR405 shorted, which burned open resistor R432, thus eliminating the +27.2V supply. Without the +27.2V supply, the receiver achieves start-up, followed instantly by shut-down.

# Results!

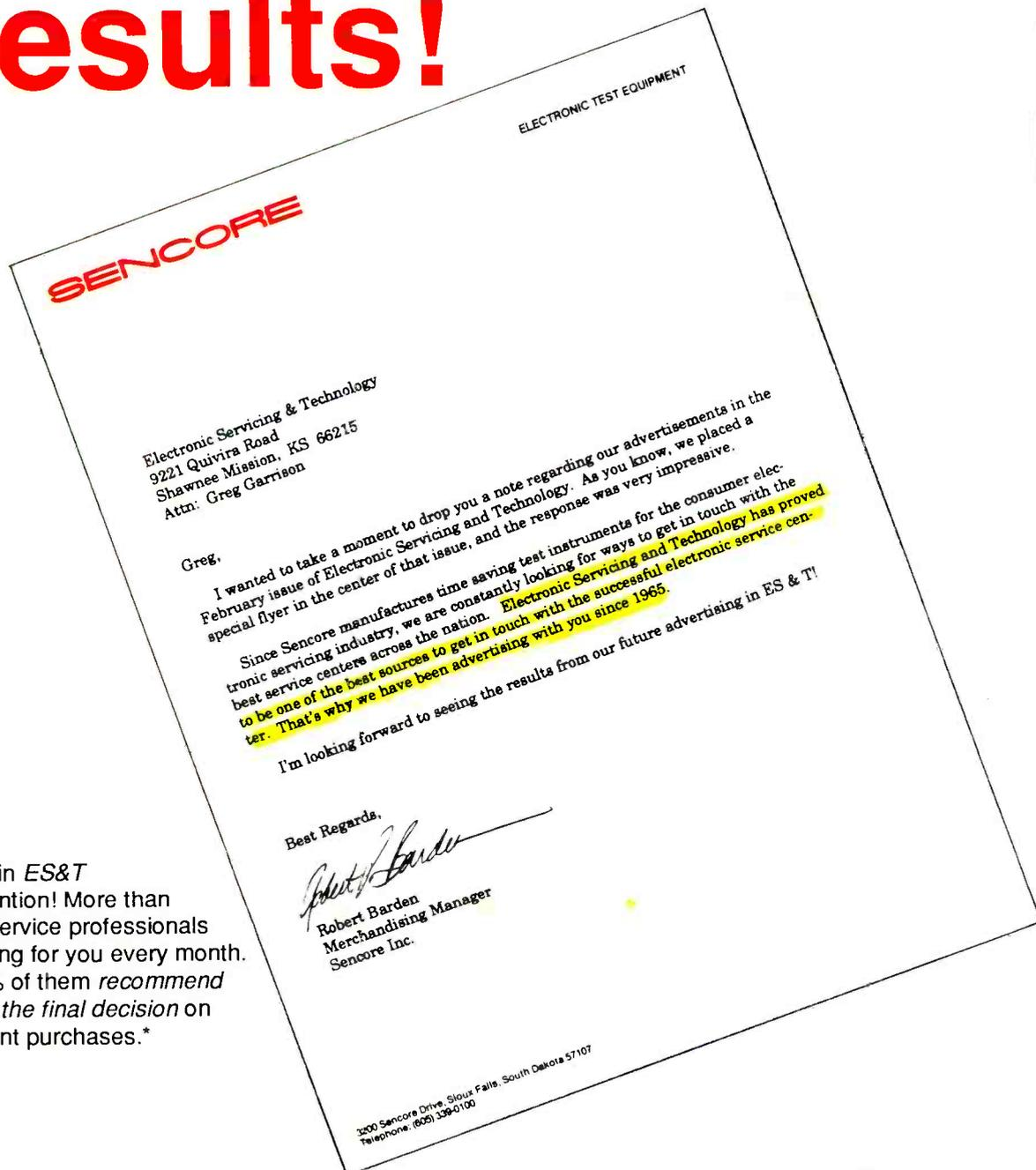

Your ad in *ES&T* gets attention! More than 40,000 service professionals are looking for you every month. And 84% of them *recommend* or *make the final decision* on equipment purchases.\*

Let *ES&T* deliver your customers to you. Call Greg Garrison today at (913) 888-4664 to reserve your ad space in the September issue.

**September Ad Closing: July 21, 1989**  
**September Materials Due: July 28, 1989**

\*Readership Profile and Purchasing Practices Study, February 1989.

THE MAGAZINE FOR CONSUMER ELECTRONICS SERVICING PROFESSIONALS

**ELECTRONIC**  
Servicing & Technology

a loss of B+ voltage from the +48.5V supply. (See Figure 5.) These measurements were verified when I traced the voltage source to diode D503 (very leaky) and resistor R521 (increased from 22Ω to about 160Ω). Replacement of the diode and resistor restored normal vertical deflection.

### Horizontal lines

Unwanted horizontal lines in the picture sometimes are produced by defective filter capacitors or increased-value resistors that bring B+ from a horizontal-deflection-powered source. Sometimes the undesired lines will be at one side of the picture, or the picture will drift out of horizontal lock.

First check all supply voltages that are

connected to the IC or transistor horizontal oscillator. The cause of extremely high B+ voltages (not likely) or too low voltages must be identified.

During our tests, a Sony SCC-340A began operating with out-of-lock horizontal lines replacing the picture. (See Figure 6.) Before an hour had passed, the picture drifted back into proper locking with a normal picture. The +11.38V source for the horizontal-sync function measured only +4.7V. Diode D514, resistor R552 and coil L501 tested OK. When I paralleled 330μF C536 with another capacitor of equal value, the voltage increased to normal. (Of course, turn off the ac-line power before attaching any large capacitor for test. Otherwise, the voltage

surge might damage an IC or transistors that operate from that B+ source.)

After C536 was replaced, I could rotate the RV501 frequency control from end to end without losing horizontal lock. This is proof of excellent and stable locking.

### Incorrect screen voltages

Symptoms of incorrect screen voltages include a dark screen with only the highlights visible, or a near-normal picture when the brightness control is at maximum or the screen control has been reset for a higher than normal voltage. In such cases, the first step should be readjusting the color-temperature controls in a recommended set-up procedure for a normal white raster. These adjustments include the screen control, video-drive controls and bias controls.

If the picture cannot be brought up to the usual brightness or if the picture remains blurry, suspect and test for incorrect screen voltages, a defective focus circuit or a weak CRT.

On the screen of an RCA CTC71A, the picture was dark and blurred. Voltage measurements at the CRT socket revealed low screen voltage. (See Figure 7.) The screen-voltage circuit was traced back to a +800V supply that was powered by a T401 flyback winding. When the components were checked, diode CR106 measured leaky during ohmmeter tests.

When the low dc voltage is measured at the boost- or screen-voltage source, sections of the raster's left side might be too black. Often the cause of these dark vertical bars at the left is an open filter capacitor in the screen or boost circuit when the circuit is powered by horizon-

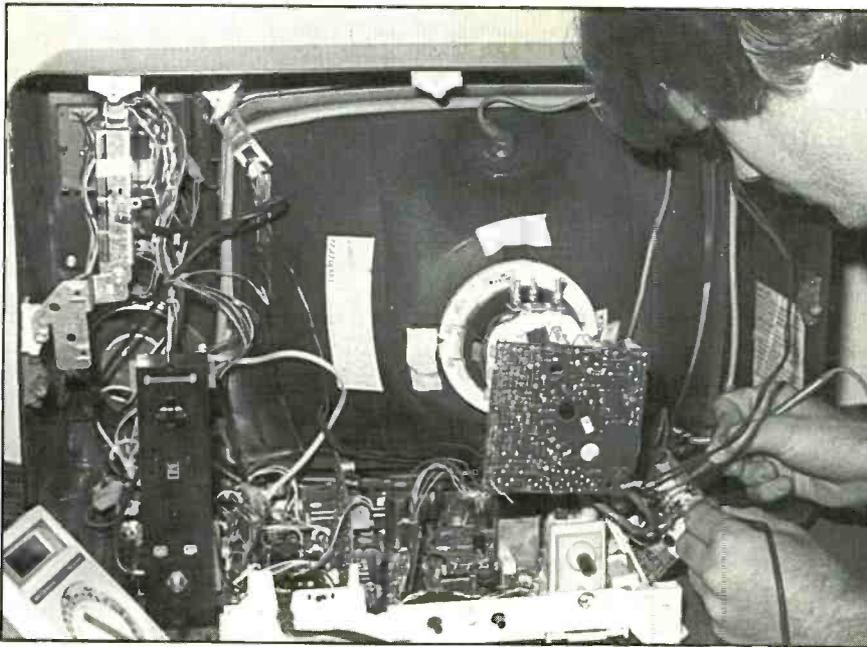

An electronics servicer is using a digital meter to check low-voltage B+ supplies that operate from horizontal-deflection power.

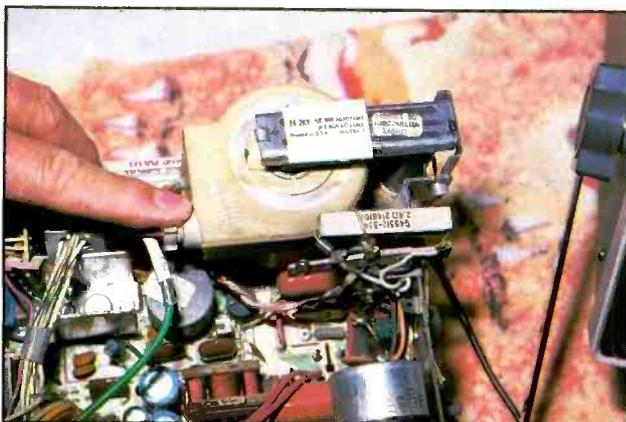

A finger points to an integrated high-voltage transformer (IHVT) that is similar to many in the latest model color TV chassis. All high-voltage diode rectifiers are located inside the transformer (flyback).



The location of SCR100, the SCR regulator, is shown by a pointing finger. Look above and to the right for the flyback transformer in this photograph.

tal pulses. This insufficient filtering produces an unwanted waveform that blanks the left side of the raster. Usually the low voltage and the dark side are caused by an open first filter capacitor, the one at the rectifier. Parallel the suspected capacitor with another capacitor of like value, and notice if the dark section disappears and the brightness increases. The capacitor should be replaced by another of the same (or slightly higher) capacitance. Above the minimum, the capacitance value is not critical. Make certain the voltage rating is sufficiently high to prevent a short. When the open filter capacitor is found in the B+ boost circuit (which has lower voltage than does the screen voltage), the original capacitance value often is  $1\mu\text{F}$ .

The left side of the raster was noticeably dark and the brightness was low in a Panasonic T126-A B&W chassis. (See Figure 8.) Adjustments of all controls did not remove the dark area. Voltage at the CRT cathode was low, and the boost voltage measured only  $+65.5\text{V}$  because C420 was open. C420 is rated at  $1\mu\text{F}$ , but I replaced it with a  $5\mu\text{F}$  capacitor, which removed the dark bar from the left side and increased the brightness to normal.

### Unusual deflection

A 3-inch-wide vertical line was the only thing visible on the screen of a J.C. Penney CTC72P chassis. The line was visible for about five minutes and then disappeared. The high voltage was very low when measured at the CRT anode.

When scoped, the gate waveform of the trace-switch SCR (ITR101) was normal. (See Figure 9.) The gate dc voltage was  $4.5\text{V}$  and the anode tested  $+4.7\text{V}$  rather than the normal  $+35\text{V}$ . After a lot of troubleshooting, I located the basic problem in the  $+207\text{V}$  source: diode CR403 was shorted. I speculated that the shorted diode was loading down the flyback pins 4 and 1 winding, thus preventing the trace switch from operating correctly.

A new CR403 produced a full raster with a good picture.

### Summary

Overloads in horizontal scan-derived, low-voltage sources can produce many different symptoms. Excessive overloads across flyback-secondary windings often drive the receiver into shut-down. Very low brightness or excessive brightness that cannot be turned down might be caused by incorrect or

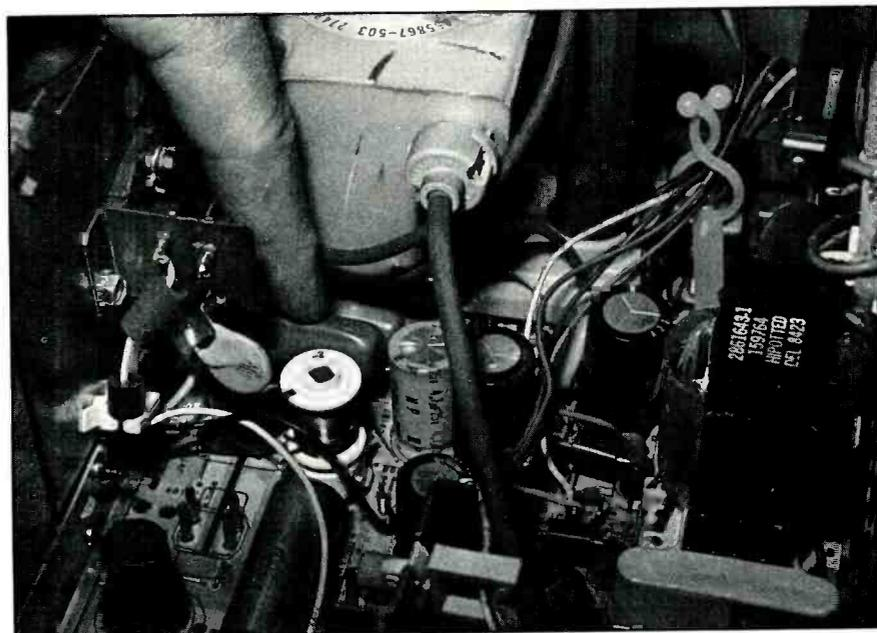

In all horizontal-deflection-powered, low-voltage supplies, always check diodes, current-limiting resistors, bypass capacitors and filter capacitors, looking for opens, shorts and leakages. The servicer in this photo is pointing out a critical capacitor.

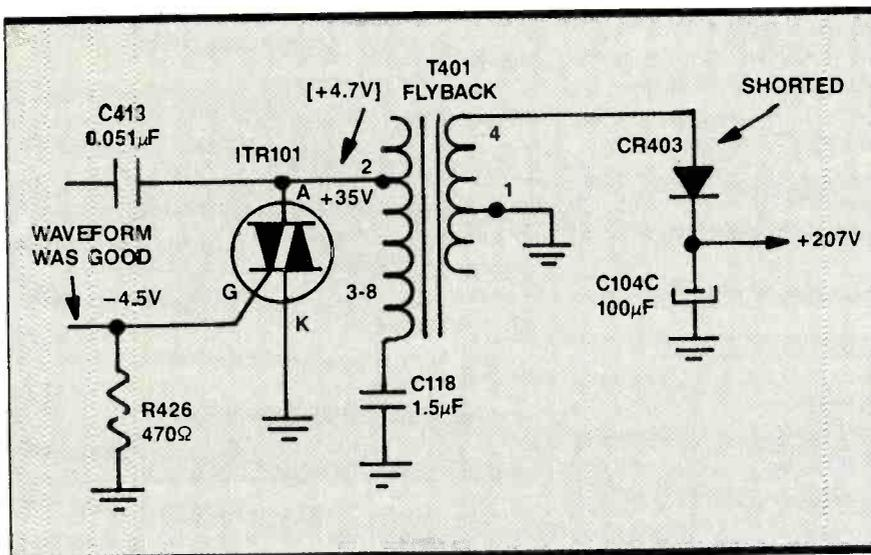

Figure 9. Nothing was visible on the screen of a J.C. Penney CTC72P chassis (refer to RCA CTC72 for the schematic) except a single 3-inch-wide vertical line. Voltages indicated that the trace-switching SCR was overloaded. A shorted CR403 in the  $+207\text{V}$  supply was identified as the problem.

low B+ from a low-voltage source. Horizontal lines in the picture or vertical problems can result from defective (usually open) filter capacitors in certain low-voltage supplies.

A leaky diode rectifier in a low-voltage supply might cause shut-down or merely eliminate that voltage. Open electrolytic capacitors can produce lines, shaded areas or critical horizontal locking. Burned or open surge resistors in a low-voltage supply might eliminate all dc voltage. Defective resis-

tors also can produce low dc voltage.

Using the DMM diode test, check transistors and diodes for shorts, opens or leakages. After a shorted diode is located, check for an open or off-value resistor or an open coil.

Remember that defective components in low-voltage, horizontal-derived B+ supplies can cause a multitude of different symptoms. Unless the problem's location is unmistakable, the servicer should first perform quick tests on the low-voltage supplies. ■

# What do you know about electronics?

## Voltage phasors

By Sam Wilson, CET

You are, no doubt, familiar with the impedance triangle shown in Figure 1. It is drawn — in this case — for a typical RC circuit (also shown in Figure 1).

If the impedance triangle is drawn to scale, the phase angle ( $\phi$ ) between the voltage and current in the circuit can be measured on the triangle. The fact that the angle is negative means the voltage lags the current. Current is usually used as the reference because the current in all parts of a series circuit is the same.

With the same current flowing through R and C, the voltage across the capacitor ( $I \times X_c$ ) is  $90^\circ$  out of phase with the voltage across the resistor ( $I \times R$ ). These voltages are shown as phasors in Figure 2. You may have used the term *vectors* for these arrows that represent voltages or other quantities. However, a vector has magnitude (size) and direction. The direction is related to the surface of the earth, such as NE and SW.

Wilson is the electronics theory consultant for ES&T.

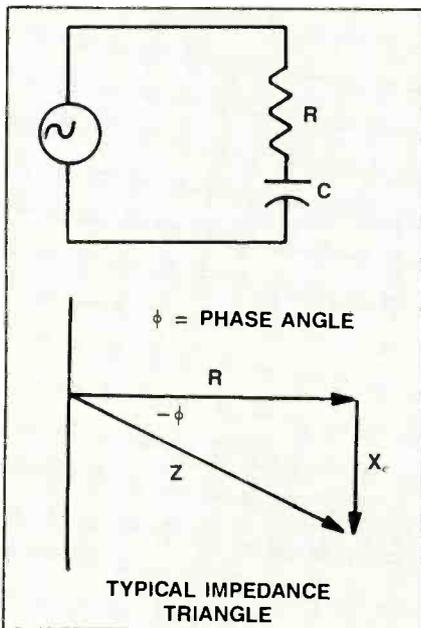

**Figure 1.** If the impedance triangle for a typical RC circuit is drawn to scale, the phase angle ( $\phi$ ) between the voltage and current can be measured on the triangle. The fact that the angle is negative means the voltage lags the current.

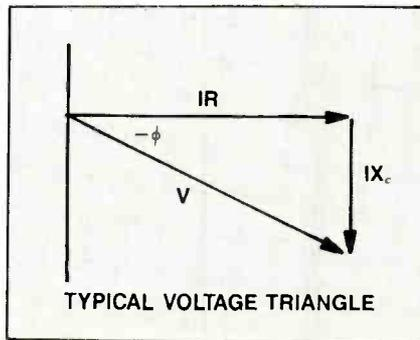

**Figure 2.** With the same current flowing through R and C, the voltage across the capacitor ( $I \times X_c$ ) is  $90^\circ$  out of phase with the voltage across the resistor ( $I \times R$ ). These voltages are shown as phasors.

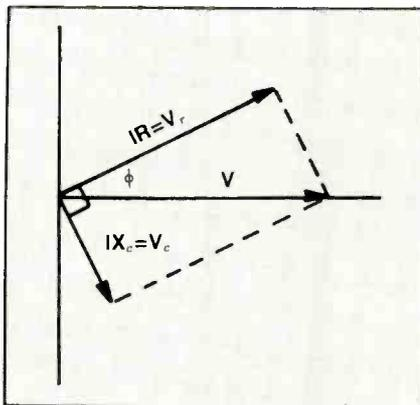

**Figure 3.** The phasors in Figure 2 can be shown with the voltage on the reference ( $0^\circ$ ) line. Note the  $90^\circ$  angle between the resistive and capacitive phasors.

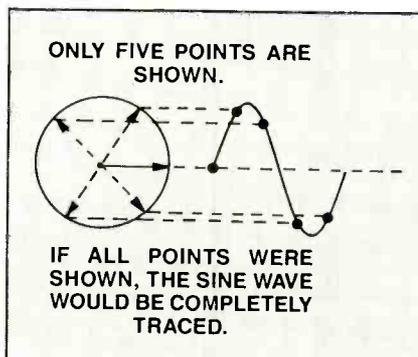

**Figure 4.** Sine-wave voltages can be represented by projecting the tips of the phasors onto a time axis as the phasors are rotated. All sine waves can be represented by phasors.

Phasors have size and a direction at a central point that is sometimes called the origin. This direction is an angle between the phasor and a horizontal reference line.

The phasors in Figure 2 can be shown with the voltage on the reference ( $0^\circ$ ) line. This is shown in Figure 3. (Note the  $90^\circ$  angle between the resistive and capacitive phasors.)

Remember that sine-wave voltages can be represented by projecting the tips of the phasors onto a time axis as the phasors are rotated. This is shown in Figure 4.

The importance of Figure 4 is in the fact that it shows how phasors and sine waves are related. In fact, all sine waves can be represented by phasors. In the following discussion, phasors will be used to illustrate sine-wave relationships in circuits.

### Representing an RC differentiator

There are several facts to keep in mind regarding the phasor diagram:

- The output of a differentiator is the voltage across the resistor ( $V_R$ ).
- In a true differentiating circuit, the voltage across R ( $V_R$ ) must be  $90^\circ$  out of phase with the applied voltage ( $V$ ).
- When you increase the capacitance of a capacitor, you decrease its capacitive reactance. If you make the capacitance infinitely high, you replace C with a straight piece of wire.

In the following examples, the applied voltage ( $V$ ) is constant. In other words, the length of its phasor is constant.

Keeping these things in mind, we will first try to get the phasor for the voltage across the resistor closer to  $90^\circ$  by increasing C. (See Figure 5.) That decreases the capacitive reactance and rotates the resistive phasor toward the applied voltage. You can see that this doesn't work because the phase angle should be getting closer to  $90^\circ$  and all we have accomplished is reducing the phase angle.

Next we will try reducing C. That will increase the capacitor voltage phasor ( $V_C$ ) and rotate the phasor for the

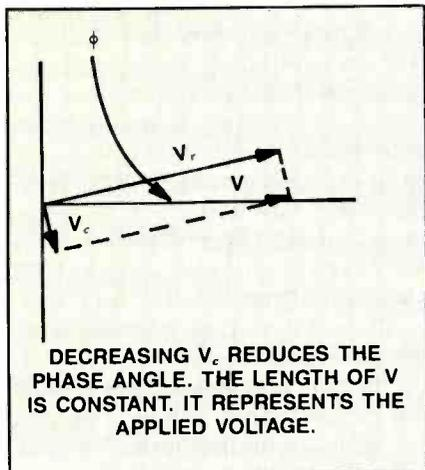

**Figure 5.** If you increase  $C$  to try to get the phasor for the voltage across the resistor closer to  $90^\circ$ , you will decrease the capacitive reactance and rotate the resistive phasor toward the applied voltage. As the figure shows, the phase angle is actually reduced.

voltage across the resistor counterclockwise. (See Figure 6.) Now we are getting closer to  $90^\circ$ . However, note that the length of the voltage phasor is decreasing. If we go all the way to zero capacitance (an open circuit) and keep the applied voltage the same, the resistive voltage phasor goes to zero. The closer we get to  $90^\circ$  with the resistive phasor, the shorter it becomes.

There is no way to get the resistive phasor positioned at  $90^\circ$  with respect to the applied voltage and, at the same time, have a measurable output voltage. To get a full  $90^\circ$ , the resistive phasor ( $V_R$ ) would have to be reduced to zero!

In a differentiating circuit, the output voltage is taken across  $R$ , so the  $90^\circ$  phase condition can only take place when the output of the differentiating circuit is zero and, at the same time, the resultant phasor ( $V_R$ ) no longer exists. All of the applied voltage, in that case, would be across the capacitor.

The message here is clear: You can't get true differentiation from an RC circuit. However, you can get very close.

### The op-amp differentiator

By adding an operational amplifier,

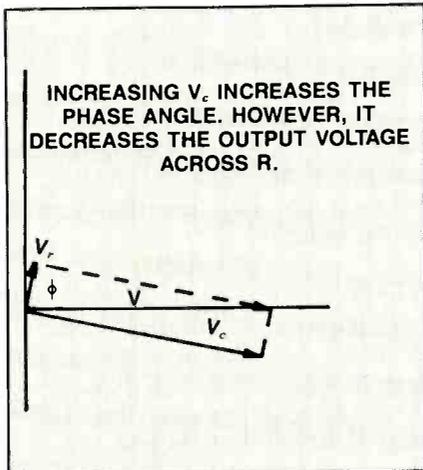

**Figure 6.** This diagram shows whether reducing  $C$  will make the phasor for the voltage across the resistor closer to  $90^\circ$ . Reducing  $C$  will increase the capacitor voltage phasor ( $V_c$ ) and rotate the phasor for the voltage across the resistor counterclockwise. However, note that the closer you get to  $90^\circ$  with the resistive phasor, the shorter it becomes.

the differentiator becomes a better circuit. This arrangement is shown in Figure 7.

As I have pointed out in previous articles and in my monographs, op-amp circuits can always be analyzed on the basis of the virtual ground. The location of this point is illustrated in Figure 7.

The op-amp will always do whatever is necessary to keep the virtual ground at 0V.

Consider what happens when a pulse is applied to the input of that circuit. This situation is shown in Figure 8. At point (a), the voltage rises rapidly to point (b). That, in turn, produces a rapid, positive-going voltage at the virtual ground (VG). To get that voltage back to 0V, the op-amp feeds a pulse from the output to the virtual ground.

The feedback pulse is negative, so when it is added to the positive rise from the input, it cancels the pulse. That keeps the virtual ground at 0V. The opposite feedback pulse occurs when the input voltage goes from C to D.

The polarity of the differentiator out-

## ATTENTION VCR TECHNICIANS



### VCR REPAIR PARTS KIT

Now you can do most of your VCR repair jobs the **same day**. Parts Express VCR Parts Kit makes this possible. It contains over 45 of the most commonly used parts to repair RCA, Hitachi, Fisher, Sanyo, Lloyds, Panasonic, Sony, Sharp, JVC, Samsung, TMK, GE, Magnavox, and more. Idler assemblies, pinch roller, sensing transistors, switches, and lamps are included in this comprehensive kit. You also save over \$20.00.

Kit contains replacements for: Sharp (2) NDL0005, (2) NDL0006 (1) NPLY V0051 Panasonic (2) VXP0329, (2) VXP0401, (2) VXP0344, (2) VXP0521 RCA (1) 150614, (1) 164113, (1) 150650 Hitachi (1) 6-1311 Fisher/Sanyo (1) 143-0-4234-00300 (2) 143-0-4804-00100, (1) 143-0-4904-00900, (1) 143-0-741T-20002 RCA/Hitachi (2) up/down switch, (5) 161757 sensing transistors Panasonic lamps, (2) XAMQ27P150W, (5) XAMV0019, (5) XAMV125 (1) Molybdenum grease. Normal dealer cost of over \$110.00 (All parts are available individually for reorders.)

Order #  
400-950

**\$89.95**

Plus shipping



### VCR IDLER TIRE KIT

This popular kit contains 170 of the most popular idler tires (10 each of 17 different sizes). With this kit in your stock room, you can do over 90% of VCR repair jobs the same day, saving time and money! Also included is our comprehensive cross reference listing over 80 manufacturers' assembly numbers and over 200 model numbers. A \$400.00 retail value. (All tires are available individually for reorders.)

Order #  
400-900

**\$55.00**

Plus shipping

**FREE  
CATALOG**



**Parts  
Express**  
International Inc.

CALL TOLL FREE

**1-800-338-0531**

340 E. First St., Dayton OH 45402  
Local—1-513-222-0173

Circle (8) on Reply Card

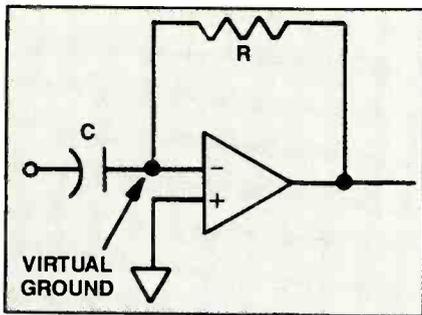

**Figure 7.** With the addition of an op-amp, the differentiator becomes a better circuit. Op-amp circuits can always be analyzed on the basis of the virtual ground. The op-amp will always do whatever is necessary to keep the virtual ground at 0V.

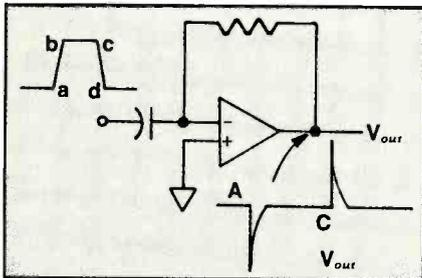

**Figure 8.** When a pulse is applied to the input of that circuit, the voltage at point (a) rises rapidly to point (b). That, in turn, produces a rapid, positive-going voltage at the virtual ground (VG). To get that voltage back to 0V, the op-amp feeds a pulse from the output to the virtual ground. Because the feedback pulse is negative, it cancels the pulse when it is added to the positive rise from the input.

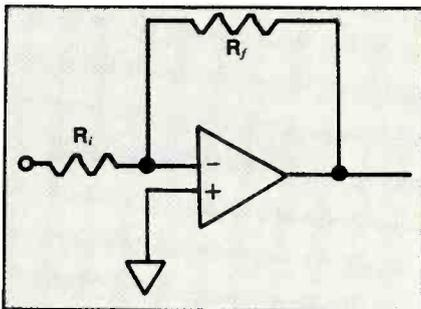

**Figure 9.** The gain of an op-amp circuit is roughly equal to the feedback impedance divided by the input impedance. In the traditional amplifier, the voltage gain ( $A_v$ ) is given by the equation  $A_v = -R_f/R_i$ .

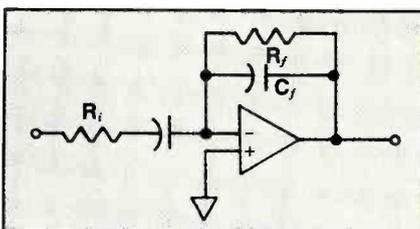

**Figure 10.** To keep the circuit shown in Figure 7 from breaking into oscillation at higher frequencies, you must reduce the amplifier gain. In this revised circuit, the input resistor ( $R_i$ ) increases the input impedance. The feedback capacitor ( $C_f$ ) decreases the feedback impedance as the input frequency is increased. The overall result is a decrease in gain and a reduced tendency to oscillate.

put is the reverse of what you would get in a simple R-C circuit. However, the shape of the output signal is correct. The output signal would have to be inverted to get the correct polarity.

### An improved version

The circuit in Figure 7 works well in theory, but when you build one, you find that it has a nasty habit of breaking into oscillation at higher frequencies. That is easy to understand.

The gain of an op-amp circuit is roughly equal to the feedback impedance divided by the input impedance. In the traditional amplifier in Figure 9, the voltage gain ( $A_v$ ) is given by the equation

$$A_v = -R_f/R_i$$

In the circuit shown in Figure 7, the input impedance decreases (because of the lower capacitive reactance) as the frequency goes up. At high frequencies, the input impedance is very low, so the ratio of the feedback impedance to the input impedance becomes very high. That results in a very high gain.

If you have a function generator, you can easily demonstrate the frequency instability of the circuit in Figure 7. Use a  $0.05\mu\text{F}$  capacitor and a  $2.2\text{k}\Omega$  feedback resistor. Start at  $1\text{kHz}$  with a triangular input wave (not a sawtooth).

If you're having a good day, a triangular-wave input should produce a square-wave output. As you increase the frequency, the leading edge of the square wave will overshoot. A further increase will cause ringing at the leading edge. That indicates that oscillation is taking place.

How do they get around that problem? They reduce the amplifier gain. The revised circuit is shown in Figure 10.

The input resistor ( $R_i$ ) increases the input impedance. The feedback capacitor ( $C_f$ ) decreases the feedback impedance as the input frequency is increased.

The overall result is a decrease in gain and a reduced tendency to oscillate.

### Found and lost

I have sent many, many letters to technician friends trying to locate two technicians I knew in the past. My phone bill looks like the city directory.

For all of you who promised to help — I found Dan Loper a couple of months ago. (It turns out that he only looks in his mailbox once every six months.) I still haven't found Bob Rosandich. ■

### The good old days

Re: "Hope for Better Days," your April 1989 editorial, I believe the better days have been here all the time.

My own common sense tells me one thing about TV — the picture tube is the next thing to go in a very short time. There goes the section that is and ever was the most failure-prone item.

I'm sure that the most failure-prone item of the future will be the audio output section. We had needed about 75W to make the picture, about 8W to make the sound, and about 3W to handle everything else. Those 450W color TVs are going to come down to about 15W. I am sure you realize what that means.

Also, witness an article that describes the making of a solid film for electrolytic capacitors instead of the wet film that was used. There goes the capacitors we replace by the handful each month.

What have we got left? Well, there's the lightning storms (I rub my hands at the approach of a thunderstorm); the accidental spillage of a soft drink into the works; the curiosity of the precious siblings; the invasion of electronics into everything; the reluctance of consumers to learn the mind-boggling fancy controls.

I have and always will service anything that comes into the store. I've even got a business name to reflect what I do: Eugene's Carry-In.

Just about anybody will gamble a bit of money to get their favorite item repaired. There's your chance! Get a deposit of reasonable proportions to pay for your efforts to look at the equipment, and be very honest with the owner. I get a turn-down rate of about 10% and have been paid for it.

**Eugene Spooner, CET, AAS  
Charlotte, NC**

### Tracking the sun

I read with interest Mr. Kluge's article, "Understanding Sun Transit Effects," published in the February 1989 issue of *ES&T*. He specified for three latitudes the peak dates, spring and fall, for the effects. He further noted that, barring some celestial upheaval, these peak dates would be the same each year.

Being an ex-science teacher, I was bothered by this contention and consulted with Dr. Ira Dubins, professor of earth sciences at our campus, who was similarly perplexed. He concluded that

there was an apparent failure to consider variations in the vernal and autumnal equinoxes. He provided the following information:

Equinoxes	
<b>1987</b>	
March 21, 3:52 a.m.	Sept. 23, 1:45 p.m.
<b>1988</b>	
March 20, 9:39 a.m.	Sept. 22, 7:29 p.m.
<b>1989</b>	
March 20, 3:28 p.m.	Sept. 23, 1:20 a.m.
<b>1990</b>	
March 20, 9:19 p.m.	Sept. 23, 6:55 a.m.

It should be concluded that if the sun's crossing of the equator can vary over nearly a 3-day period, the location of the sun at a particular latitude in that same year will be subject to the same variation. In light of this fact, the peak dates to which Mr. Kluge referred cannot be the same each year.

**Joseph S. Gardiner**  
 Director, Instructional Resources  
 Center  
 State University of New York  
 Oneonta, NY

*Thank you for your interest in my article. The point you make — that the equinox can vary over nearly a 3-day period — is a valid one. Dr. Dubins also is correct in concluding that I failed to consider these variations of the vernal and autumnal equinoxes when defining the peak days.*

*However, the point I would like to make is this: The total period during which the danger exists to an operator can extend from six to seven days. The peak day is important only in that it defines the week during which the operator should beware of intense solar flux impinging on the feedhorn. It behooves the operator to be cognizant of the feedhorn's shadow during this week-long period if the antenna is pointed toward the sun.*

*From the figures you provided in your letter, the maximum peak-day variation from 1987 to 1990 is only 18 hours, 16*

*minutes; the minimum variation is less than 6 hours. Nevertheless, I'm sure that the readers of ES&T will appreciate this additional information you have offered.*

**James E. Kluge**

#### Computers for small businesses

I follow Mr. Lynott's Business Corner with much interest; because I run a "tiny" 2-man operation, I usually find it helpful and enlightening. I must, however, disagree with the views he expressed on the column, "Using the Computer in the Shop," published in May 1989.

I, like most, started on a practically non-existent budget. Spending \$2,000 on a computer system seemed unreasonable and was out of the question. Being a computer enthusiast and having worked in the field, I realized the great advantage of having one to help out in the shop. I find that the "now seriously outdated" 8086- and 8088-based systems are going very, very cheap — some as low as \$500 and even cheaper if you are handy enough to put it together yourself. Think of the uses you might have for a shop computer. I keep track of the sets in the shop and their status; I organize the calls for the day; I keep all the expenses we have in there, as well as the income. I have a small database to keep a "help" file, with common failures of certain models. And lastly, it functions as a word processor. I could not think of any application that would be so crucial to the operation as to NEED a hard drive — a 40Mbyte drive, no less. It's nice to have one and you can't compare the access speed and the convenience, but it's hardly a must.

There's enough software out there to take us well into the next century. Again, I fail to see the need to shave 50µs of the access time with an updated version of the same program. There are excellent databases, spreadsheets and word processor software available for the "outdated" 8086/8088 machines at very reasonable prices.

I get the feeling Mr. Lynott is overlooking the really small guys, like my partner and I. We also want to run our business competently and be successful. Obviously, a 2-man shop can't afford to spend \$2,000 on a printer, let alone up to \$5,000 for a system.

## THE MAGNUM INDESTRUCTO® SERIES

IN HIGH VISIBILITY,  
SAFETY YELLOW  
AND/OR JET BLACK



High Tech,  
specially-  
designed,  
Tool Carrying  
cases.

**Choose from eight models**  
**Select from two designs—**  
**Specify your color combinations . . .**  
**High visibility safety yellow with black**  
**hardware; and high-tech jet black.**

The "Magnum" series sets the pace . . . with unique and original SAFETY YELLOW HIGH VISIBILITY CASES and/or HIGH-TECH JET BLACK CASES. High impact, high density INDESTRUCTO® polyethylene. Have so many features that you must see these cases for yourself. Every feature to make "Magnum," the best tool carrying cases available anywhere. Get the facts from your Chicago Case rep. or, communicate with:



**Chicago Case Co.**

4446 S. Ashland Avenue, Chicago, IL 60609  
 (312) 927-1600 FAX: (312) 927-2820  
 Circle (9) on Reply Card

I run my business on what Mr. Lynott (and most of the civilized world) would consider a toy. I'm using a Commodore 64 with an Okidata printer and two 1.3M floppy drives. The software is mostly homebrew.

**Marcos Virido**  
Brooklyn, NY

*Many thanks for your thoughtful letter. I appreciate you taking the time from your business to write. Be assured that I'm not "overlooking the small guy." I'm one myself, and Business Corner is specifically aimed at the small electronics service company.*

*Your points are well-taken, particularly from the standpoint of someone like yourself who is computer-literate and capable of writing your own software for basic tasks. It is, as you have proven, possible for a talented person to put together a minimum, entry-level system for less than the amounts I discussed in my column. However, I must stand by my comments for several reasons.*

*My work with service dealers centers around one basic goal: growth in sales and profits. The systems you mentioned as being available for as little as \$500 or less are available at that price for the very reason that they are limited in their capacity to accommodate growth beyond the most basic functions. Although such a system may seem adequate while your business is so small, I suspect that it won't be long before you will be looking around for a system that will support all of your business needs, particularly if you enjoy the growth that I hope is in your future. I wish you could meet a few of the service dealers I know who put together the lowest priced system they could find for their businesses, only to scrap them in favor of systems that were more appropriate (and profitable) soon after.*

*In my view, a computer system for a service dealer is a tool just like a scope or a signal generator. It's always possible to go the minimum price route, but that is usually not the best choice. I want to stress again that my column did not recommend an advanced computer system that would cost many thousands of dollars. I do feel, however, that one step above the barest minimum will be the best long-term investment.*

**William Lynott** ■

# Test your electronics knowledge

By Sam Wilson, CET

NOTE: There may be more than one correct choice for the multiple-choice questions.

1. What is another name for a beta-squared amplifier?

2. Which of the following are not characteristics of transformer-coupled amplifiers?

- A. low cost
- B. impedance matching
- C. can be tuned to a range of frequencies
- D. step up or step down voltage
- E. blocks dc

3. Which of the following are not disadvantages of direct-coupled amplifiers?

- A. level shifting
- B. power-supply stability problems
- C. temperature stability problems
- D. poor low-frequency response
- E. ripple in the power supply can cause serious burn problems at audio frequencies

4. Which of the following are characteristics of JFET amplifiers?

- A. low partition noise
- B. low Johnson noise
- C. high input impedance
- D. high input capacitance
- E. high gate current

5. Connect the transistors in Figure A into a Darlington configuration.

Wilson is the electronics theory consultant for ES&T.

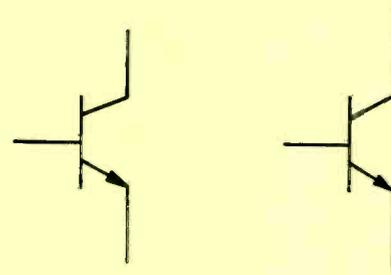

6. Write the equation for impedance matching in a transformer.

7. If you increase the gain of an amplifier, you automatically \_\_\_\_\_ the bandwidth.

8. Gate current in a properly operating JFET amplifier is

- A. dependent on  $V_{DD}$ .
- B. dependent on  $V_{DS}$ .
- C. dependent on  $V_{GS}$ .
- D. None of these choices is correct.

9. Use of degenerative feedback causes

- A. a decrease in amplifier gain.
- B. a reduction of noise and distortion.
- C. an increase in amplifier bandwidth
- D. All of the above.

10. Negative dc feedback is used to

- A. increase the bandwidth.
- B. reduce the gain.
- C. stabilize the operating point.
- D. change the phase.

Answers are on page 37.

## Answers to the quiz

Questions are on page 24.

1. Darlington amplifier. The name comes from the fact that the beta of the Darlington pair is equal to the betas of each of the two transistors in the pair multiplied together. If the transistors are identical — or nearly identical — the beta of the combination is beta squared.

2. A — low cost. All the other choices are characteristics of transformer-coupled amplifiers.

3. D — poor low-frequency response. All the other choices are disadvantages of direct coupling.

4. A, C and D — low partition noise, high input impedance and high input capacitance. These are typical characteristics of the JFET as an amplifier.

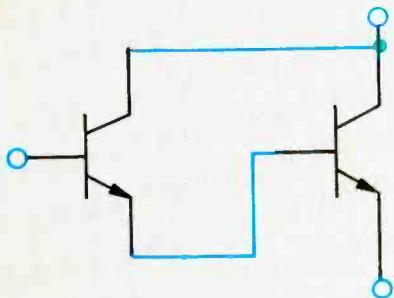

5. See Figure B.

6.  $(N_p/N_s)^2 = Z_p/Z_s$ . (This assumes 100% flux linkage.)

7. Decrease. Gain and bandwidth is called the gain/bandwidth product. It is a constant, so if you increase one, you automatically decrease the other.

8. D — None of the choices. There isn't supposed to be a gate current.

9. D — All of the choices are characteristics of degenerative feedback.

10. A, B and C — increase the bandwidth, reduce the gain and stabilize the operating point. Negative feedback is the same as degenerative feedback.

# Hot line.



Call PTS 800 Express toll free. Order direct from the world's largest inventory of quality replacement parts for T.V.'s and VCR's. One convenient source. All makes. All models. Quality backed by the industries best warranty. Just say "charge it". Call today to order or to receive your free replacement parts catalog.

**NEW**  
**DTS** **8/00**  
**EXPRESS**  
**1-800-333-PTS1**



Circle (10) on Reply Card

July 1989 *Electronic Servicing & Technology* 37

# Servicing Zenith microcomputers

## Part I: The backplane

By John A. Ross

The Zenith microcomputer is an IBM-compatible personal computer that uses a *backplane* type of design rather than a motherboard. All circuitry for the computer is contained on modular printed circuit boards that are interconnected via an interconnection backplane at the back of the computer. This setup is in contrast to IBM and compatible computers that have the processor, memory and other circuitry on a master *motherboard*, which also contains sockets into which other circuit boards, such as the monitor interface, printer interface and modem, are plugged.

To open the Zenith computer up for inspection or servicing, remove the metal top cover. To remove the cover, unscrew the seven machine screws. Two screws attach on each side of the cover while three screws fasten to the back of the cover. After removing the screws, slide the cover toward the rear of the microcomputer and gently lift the cover up. Removing the cover exposes the backplane, power-supply module, at least four printed circuit cards, disk drives and interconnecting cables.

Referring to Figure 1, some differences between the Zenith microcomputers and some other name-brand microcomputers become readily apparent. Zenith computers are designed to be easily serviced. Although this block diagram features an early Z-158PC series microcomputer, Zenith continues to follow this formula in their present line of desk-top microcomputers.

Instead of employing the commonly used motherboard concept in the Z-158 and other models, Zenith uses a backplane as an interconnection between the various cards that make up the microcomputer designs. As a matter of note, the motherboard concept surfaces in dif-

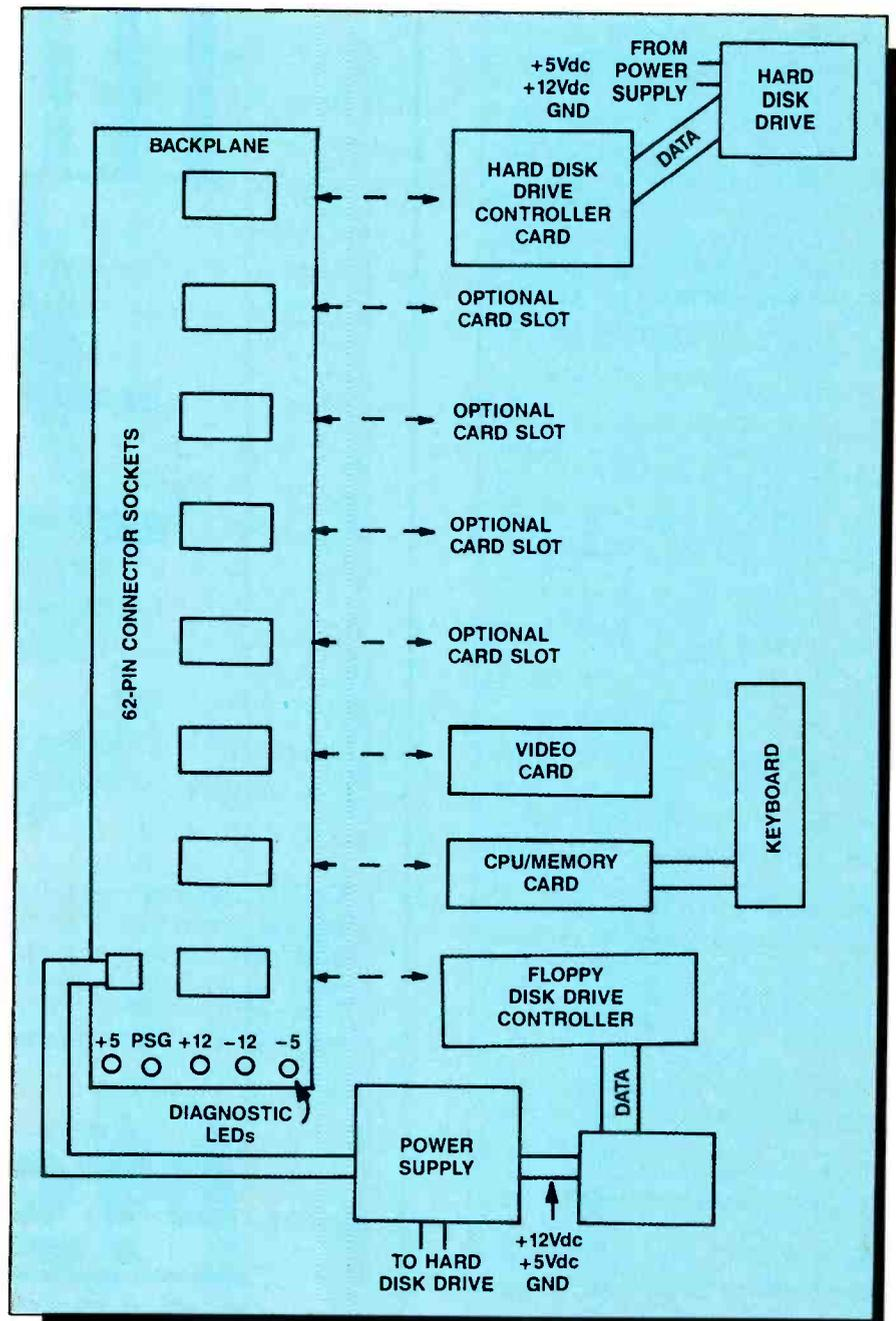
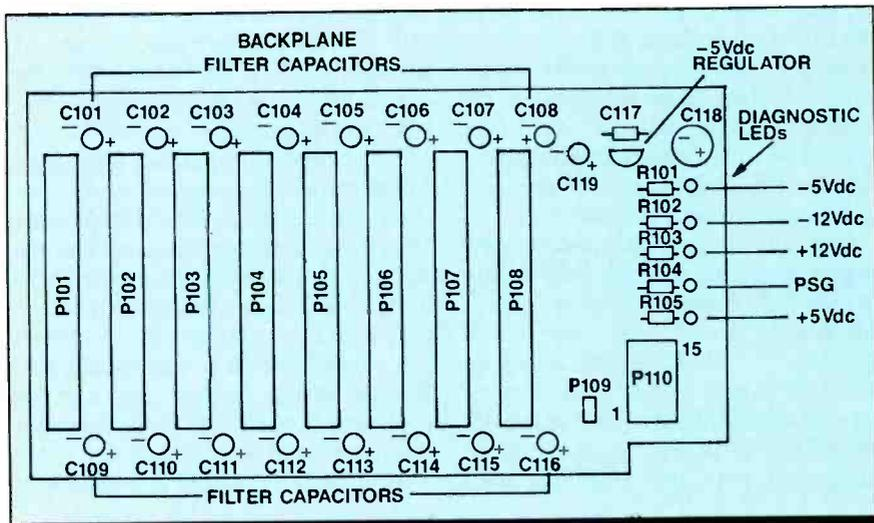
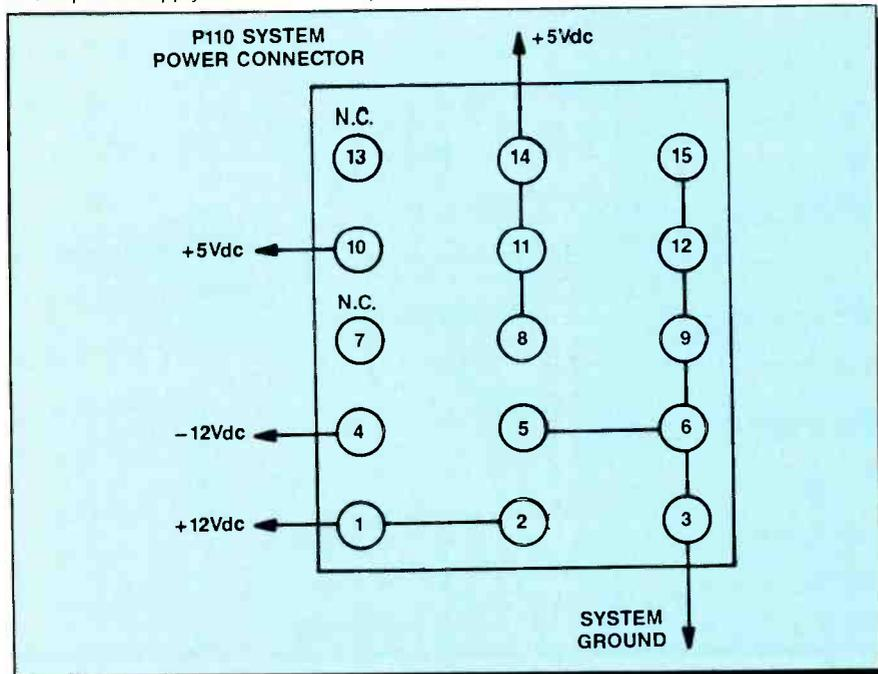

Figure 1. Instead of employing the commonly used motherboard concept in the Z-158 and other models, Zenith uses a backplane as an interconnection between the various cards that make up the microcomputer designs.

Ross is a technical writer and a microcomputer consultant for Fort Hays State University, Hays, KS.



**Figure 2.** The backplane contains two Molex connectors, five LED indicators and their respective current-limiting and voltage-dropping resistors, a  $-5\text{Vdc}$  regulator, filter capacitors and eight input/output (I/O) expansion slots. P110, a 15-pin Molex connector, couples the backplane to the power supply of the microcomputer.



**Figure 3.** The pin-out diagram shows that three voltages —  $+5\text{Vdc}$ ,  $+12\text{Vdc}$  and  $-12\text{Vdc}$  — and the system ground connect from the power supply through the connector to the backplane.

ferent series of Zenith microcomputers.

### The backplane configuration

Pictured in Figure 2, the backplane contains two Molex connectors, five LED indicators and their respective current-limiting and voltage-dropping resistors, a  $-5\text{Vdc}$  regulator, filter capacitors and eight input/output (I/O) expansion slots. Although this backplane resembles an ordinary circuit board, it features multilayer construction. Used on the other printed circuit cards in the microcomputer as well, this type of construction calls for soldering and desoldering techniques different from those techniques used for the common single-layer printed circuit boards. Technicians may find an excellent reference to these techniques in the May 1987, August 1987 and the May 1988 issues of **Electronic Servicing & Technology**.

Located in the middle-right side of the backplane, a 15-pin Molex connector couples the backplane to the power supply of the microcomputer. Figure 2 shows the physical location of this connector, labeled P110. Figure 3 displays the pin-out diagram. Three voltages —  $+5\text{Vdc}$ ,  $+12\text{Vdc}$  and  $-12\text{Vdc}$  — and the system ground connect from the power supply through the connector to the backplane. On the backplane, the  $+5\text{Vdc}$  is connected via lines B3 and B29, the  $-12\text{Vdc}$  is connected through line B7 and the  $+12\text{Vdc}$  is connected via line B9. Lines B1, B10, and B31 establish the ground plane.

Because of the need for heavy current-carrying capacity, this design uses multiple sets of pins for the ground and for two of the three voltages. Along with the 15-pin connector, the backplane also contains a smaller Molex connector. Because the video driver board of the microcomputer requires  $+12\text{Vdc}$  for operation, Zenith built in a separate

2-pin connector, labeled as P109, for this purpose.

### The LED indicators

Five LED indicators give the technician a feel for the start-up voltages of the microcomputer. A glance at four of the indicators, one labeled for each of the three power supply voltages and the regulator voltage, gives an indication of the presence or absence of those voltages. To check for voltage tolerance, you need only to look at the fifth indicator, labeled PSG for *power supply good*. A lit PSG indicator shows that each voltage falls within the required  $\pm 3\%$  tolerance. As we will see later, you can't rely on these indicators as a cure-all, but only as a preliminary diagnostic aid.

Each LED operates on a steady 2.5Vdc at 20mA supplied through current-limiting and voltage-dropping resistors R101 through R105. Figure 4 schematically depicts this operation. Labeled as R101 and R102 respectively, 560 $\Omega$  and 1,500 $\Omega$  resistors connect the cathodes of D101 and D102 to the required voltage bus. Two other 560 $\Omega$  and 1,500 $\Omega$  resistors, R103 and R105, connect the anodes of D103 and D104 to system ground. This return to ground

allows the LEDs to properly sense the +5Vdc and +12Vdc signals. Also, +5Vdc is connected through another 560 $\Omega$  resistor connected in series to the anode of D104.

As mentioned in an earlier paragraph, Zenith uses D104 as the *power supply good* diagnostic indicator. While the microcomputer goes through the various stages of power-up, the design of the circuit allows a few hundred seconds for power supply stabilization. Until the power supply outputs have reached complete stabilization, the cathode remains at a potential of +5Vdc. This potential, supplied through pin 10 of P110, keeps the LED extinguished. If the protective sensing circuitry of the power supply "sees" normal operating voltages, the sensing circuitry pulls pin 10 to near ground potential. At near ground potential, the LED lights and indicates normal power supply operation.

Consequently, normal operation also means triggering the only output supply voltage generated on the backplane. Integrated circuit U101 supplies a regulated -5Vdc to the bus connector at pin B5 through a 47 $\mu$ F filter capacitor labeled C118. U101 derives the -5Vdc from the -12Vdc line. Again referring to Figure 4, pin O of the regulator sends

-5Vdc to the parallel bus connector. As pin G returns the signal to system ground, pin I receives the -12Vdc filtered through a 0.01 $\mu$ F capacitor, C117, and a 2.2 $\mu$ F capacitor, C119.

### The signal bus

All of this takes us to the signal bus. On one level, the signal bus simply serves as an interconnect between the power supply, the backplane, and the CPU, video, disk-controller, I/O and memory cards. Physically, the eight identical 62-pin edge connector sockets, eight filter capacitors and the actual backplane make up the bus. Arranged with 31 pins on each side, labeled A1 through A31 and B1 through B31, the connector sockets give the microcomputer two things: IBM compatibility and the possibility of expansion with additional cards. Room for expansion sets the Z-158 and other newer models apart from those models in the Zenith line that are constructed around the motherboard design. In a later article, we'll take a closer look at possible ways to expand the capabilities of a microcomputer. Because of the identical nature of the connector sockets, the technician may insert any card in any location. Eight 33 $\mu$ F capacitors, placed between every

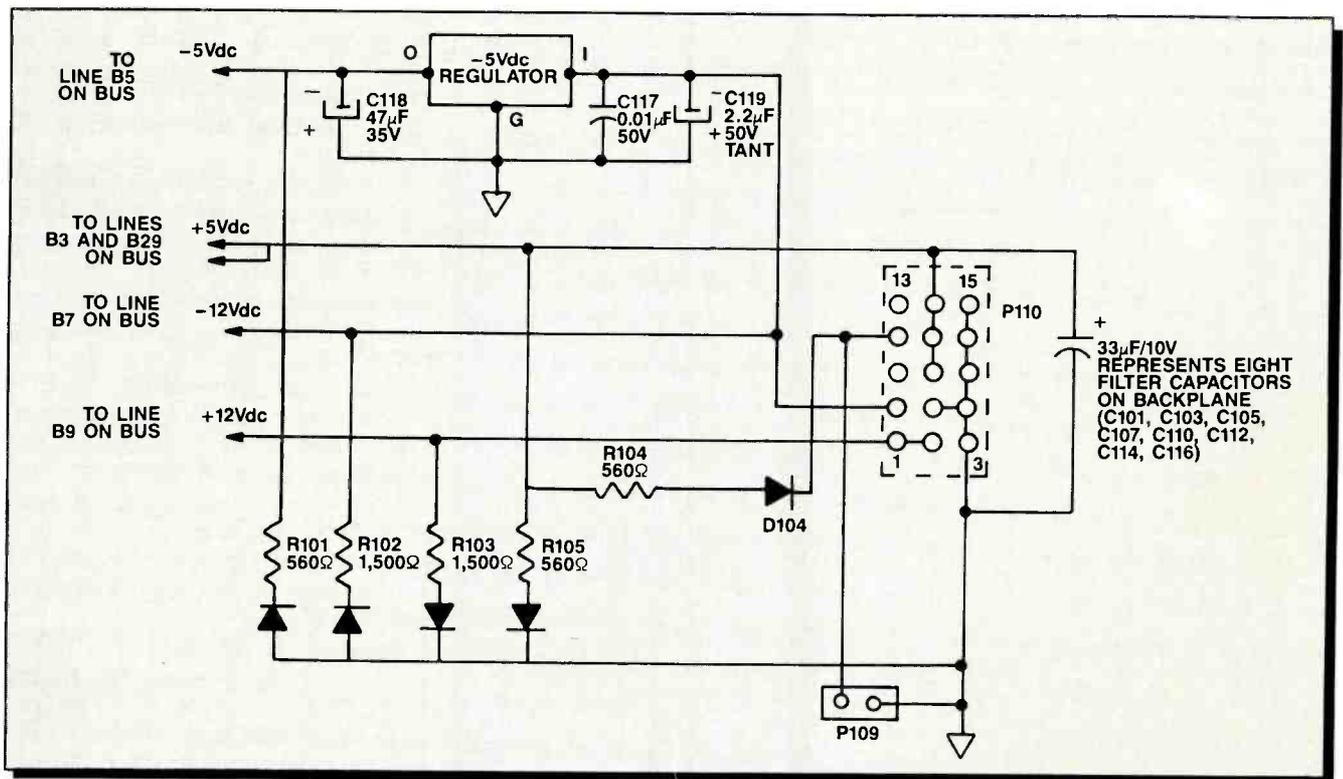

**Figure 4.** Each LED operates on a steady 2.5Vdc at 20mA supplied through current-limiting and voltage-dropping resistors R101 through R105. Labeled as R101 and R102 respectively, 560 $\Omega$  and 1,500 $\Omega$  resistors connect the cathodes of D101 and D102 to the required voltage bus. Two other 560 $\Omega$  and 1,500 $\Omega$  resistors, R103 and R105, connect the anodes of D103 and D104 to system ground. Also, +5Vdc is connected through another 560 $\Omega$  resistor connected in series to the anode of D104. D104 is used as the *power supply good* diagnostic indicator.

other pair of connector sockets, filter the +5Vdc supply voltage.

On a more complex level, the bus supplies a myriad of data to the individual cards that make up the microcomputer. Unfortunately for most technicians, learning about this data also means learning new terminology. For starters, you will have to learn the terminology that describes the bus' eight bits of bidirectional data, twenty address lines, six levels of interrupt, lines for memory, I/O read and write, and clock and timing control. Additionally, the bus provides the aforementioned operating power, a channel check line for memory error checking, and an I/O channel ready line for peripheral devices. Although these terms seem intimidating, a careful examination will show how these functions interact as the microcomputer operates.

Compatibility with the IBM design dictates the type of signals found along the bus connectors. Figure 5 shows the signal lines. At line A1, Zenith employs an I/O channel check signal. Normally, the technician will find the I/O ch.ck. signal at an active high level. If an error, indicating either a problem with memory or other I/O devices, appears along the I/O channel, the signal goes to an active low.

#### The lines of communication

For communication between the processor, memory and I/O devices, Zenith uses lines A2 through A9 of the connector to transfer eight bits of bidirectional data. Each 8-bit group equals one byte. Two bytes equals a word. Jumping ahead to microprocessors for an instant, a 16-bit processor can transfer either one or two bytes at a time. Internally, a 16-bit processor can work on or process 16-bit data or instructional codes. An 8-bit processor transfers only one byte at a time. Subsequently, we'll examine the more recent 32-bit technology. Not surprisingly, Zenith uses a microprocessor that has a 16-bit internal structure, the 80C88, in the 150 series of microcomputers. However, moving back to the bus, they employ an 8-bit data bus. Looking at this data, each line works at an active high. Significance ranges from D0 at line A9 as the least significant bit to D7 at line A2 as the most significant bit.

Line A10 shows as the I/O channel-ready line. Again normally operating at an active high level, the line pulls to an active low state to lengthen the I/O or

memory cycle. An active low state occurs with the attachment of slower peripheral devices and ensures that the line retains all data. In a normal operating condition, the active low or not ready state can hold for 10 clock cycles or 2.1 $\mu$ s.

Zenith designates line A11 as the address enable line. As with all other signals, this signal normally works at an

active high level. When at an active high, the CPU or any other devices become disabled with the direct memory access controller taking control of the line. With the DMA controller controlling the address bus, data bus and the read and write command lines, a direct memory access can take place. This particular operation allows for the transfer of information from the

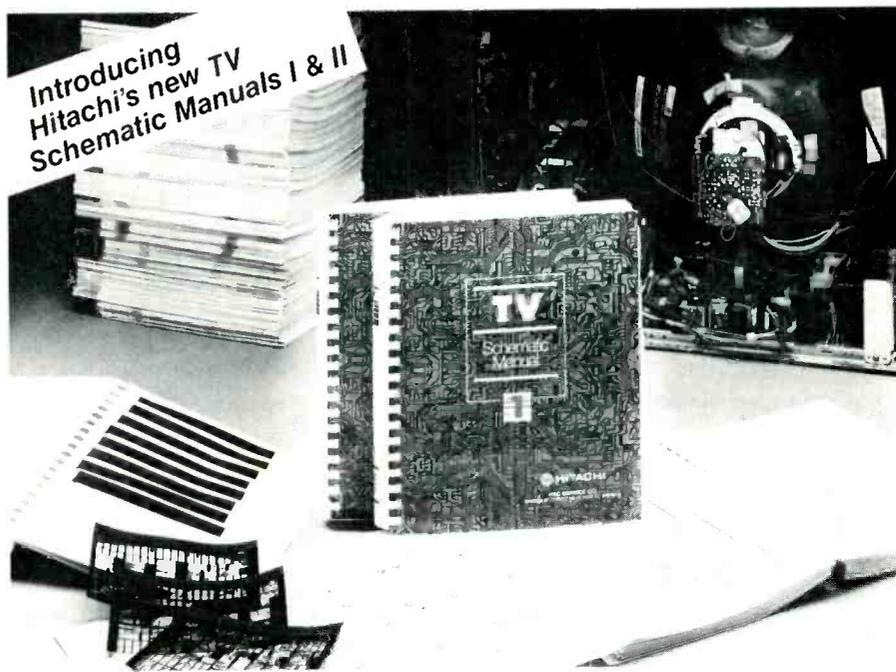

## All the technical data of 83 Hitachi TV Manuals—in just two volumes



# HITACHI

**Our new Hitachi TV Schematic Manuals give you the best of both worlds—**

With the compact storage of 32X microfiche and full-view hard copies of the items you use the most. Organized by year and model number in both formats, these volumes give you everything you need—83 models from 1975–1981. They're neatly packaged, easy to use, and economically priced.

**You'll get hard copies of:**

- Schematic Diagrams • Block Diagrams
- Printed-Circuits Board Layouts • Part Lists • Mechanical Part Exploded Views

**And get the works on microfiche:**

- Service Manuals with Technical Data and Information • Troubleshooting Tips • Revised or Supplemental Manuals • Instruction

Manuals • Parts and Service Bulletins

**Volume I covers:** 54 models from 1975–1978.

**Volume II covers:** 29 models from 1979–1981.

That's a lot of service data for a low **\$54.95** per volume! About what you would expect to pay for information on only two models. Or save even more by getting both volumes for just **\$104.00**. Take advantage of these savings now. It's a simple, cost-effective way to increase proficiency and increase profit. Also available are our VCR Volumes I, II and III.

**Call toll-free 1-800-447-2882 for your nearest Authorized Hitachi Distributor**

**HSC Service Company**

division of Hitachi Sales Corporation of America

Circle (11) on Reply Card

July 1989 *Electronic Servicing & Technology* 41

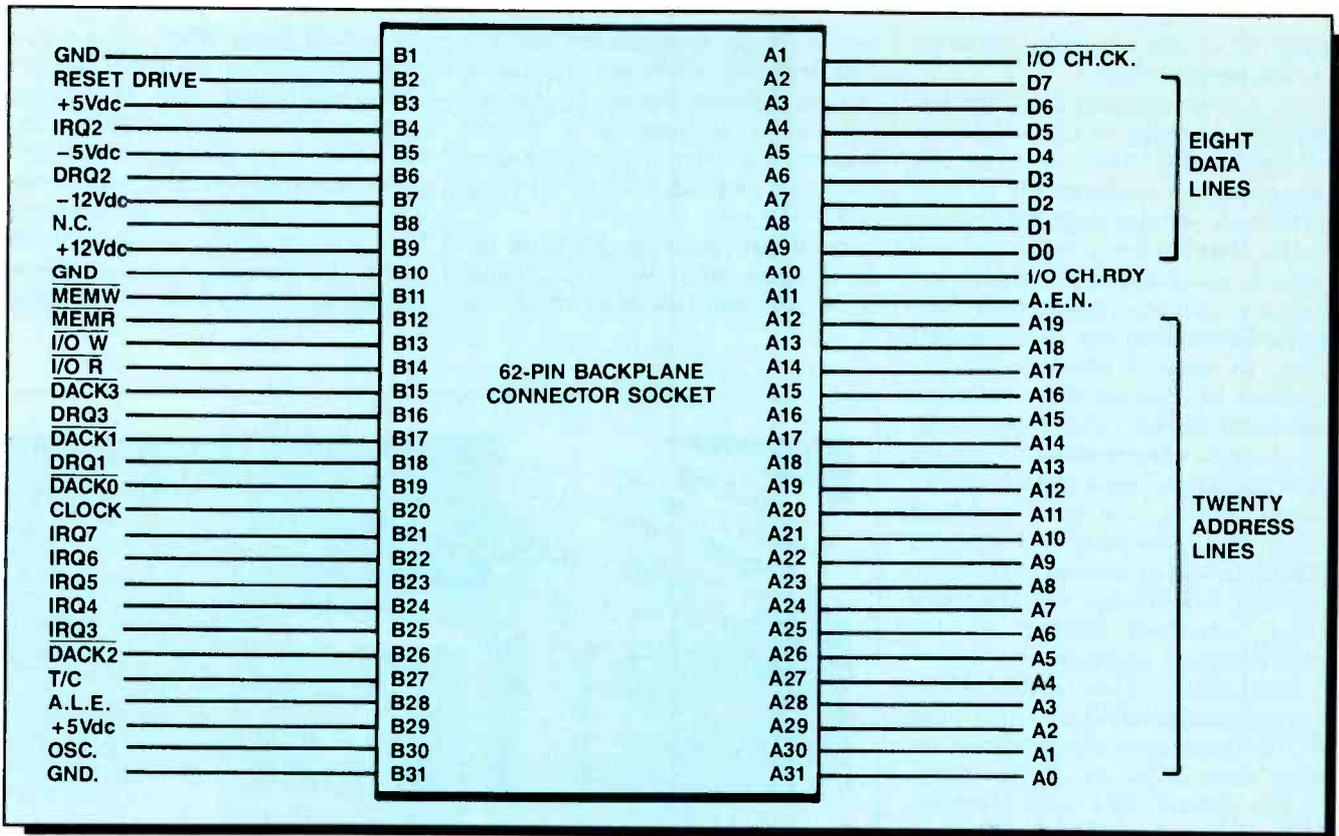

Figure 5. Compatibility with the IBM design dictates the type of signals found along the bus connectors.

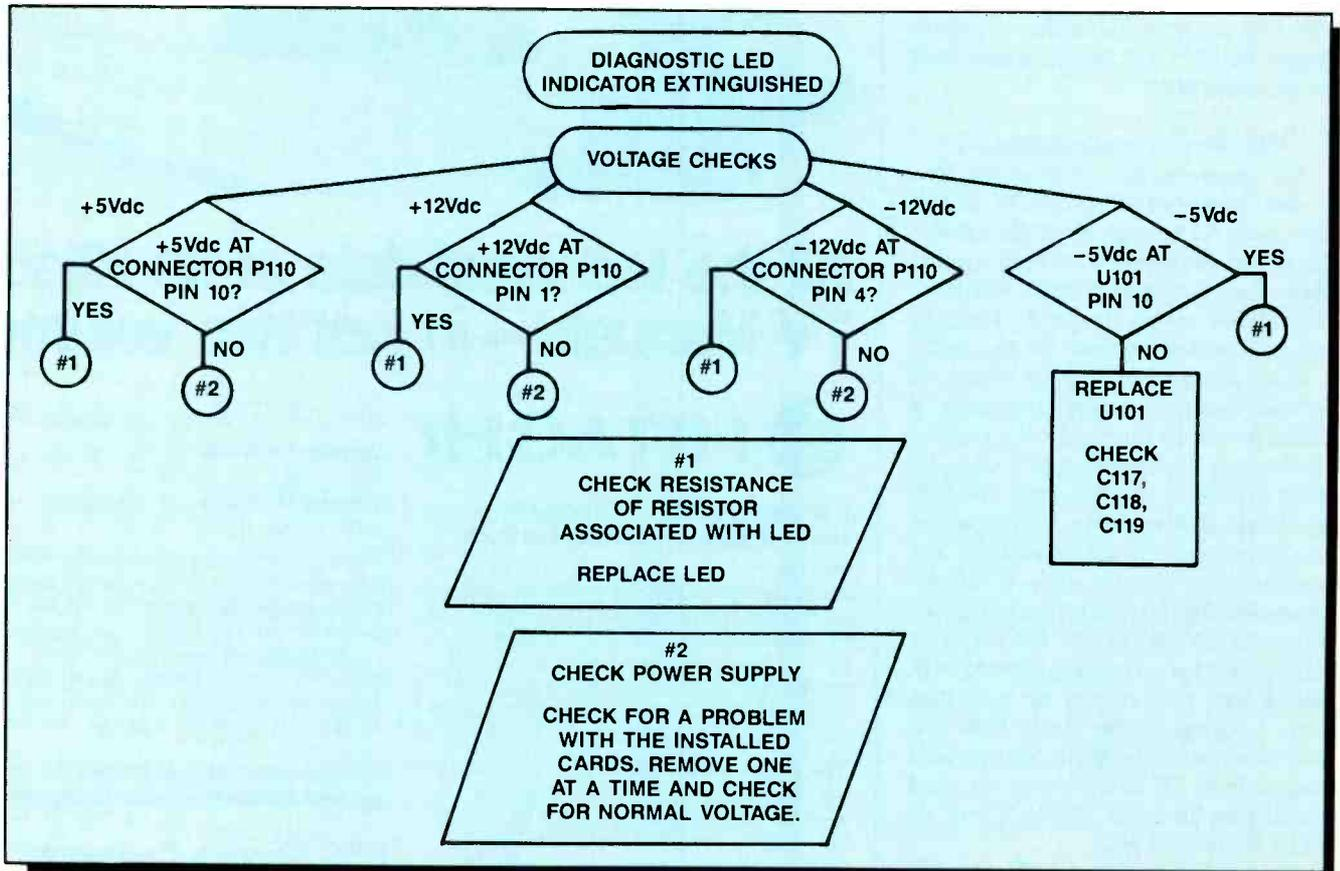

Figure 6. A preliminary check for a possible fault in the backplane connector signal operation involves simply switching the printed circuit cards from location to location. If the fault does not show, clean all edge connector contacts and inspect the backplane for poor solder connections.

processor to the memory. During the operation, the processor writes to the memory by placing data on the bus along with address and control signals. Generally, the microprocessor generates a 16-bit address code that indicates the memory storage location that will receive the data. With the address enable and the memory-write enable active, the memory performs a write operation and stores the information. On the data bus, line B11 serves as the memory-write enable line and causes the storage of information when operating at an active low condition.

Similarly, the memory-read enable line operates at an active low condition when the processor needs to retrieve data. In this operation, the processor receives either the next instruction code for the executing program or data code from the memory. Starting the operation, the processor sends the data transfer lines into an input mode and places the address location code on the address lines. Sequentially, the memory-read enable signal, found at line B12, reaches an active low state. When the memory-read enable signal reaches the active state, the memory circuit responds by placing the requested binary code on the data transfer lines. After receiving the code, the processor stores the code in an internal instruction register or into a data register. Obviously, the selected register depends on the type of code, program instruction or data sent to the processor.

#### Getting the processor's attention

Taking a closer look at the actual direct memory-access operation, you will notice several things happening in rapid sequence. When a device initiates a transfer, lines B18, B6, and B16, called the *direct memory-access request lines*, reach an active high level. At an active high level, the DMA controller receives the request for a data transfer. In turn, the DMA controller sends a signal, called the *DMA acknowledge*, through lines B17, B26 and B15 to the requesting device. With the designation of "available for user assignment," line B17 stands unused. Line B26 serves the floppy disk-drive controller and line B15 serves the hard disk-drive controller. Effectively, the acknowledge signal tells the peripheral device that the DMA controller has reached a ready state. Also, the terminal count line, B27, relays a pulse when any direct memory-access channel signal reaches the terminal. To

initiate the memory-refresh cycle, the DMA controller sends a signal through line B19 to the system random access memory.

Several important things happen when a printer, floppy disk drive, hard disk drive or some other peripheral device

---

**A detailed look at the backplane architecture gives the technician an idea of what happens during the microcomputer system operation. Although the operation detailed in the backplane description occurs within an instant, the technician needs to recognize the action of the various signals.**

---

requires attention from the processor. Comparatively, the data transfer between the devices and the processor resembles the memory transfer operations. As the name *memory-mapped I/O* suggests, the processor considers the input and output locations as memory locations.

Imitating the memory transfer routine, the processor sends input/output on the data transfer lines; it sends an address code on the address lines; and it then enables the I/O write or read signal on lines B13 or B14, respectively. Both lines serve as bi-directional lines at an active low state. When at the high or idle state, both lines send an input control signal to the processor. Receiving the input control signal from line B13, the processor latches the signal into an internal data register and loads information into the DMA controller. Receiving the input control signal from line B14, the processor begins to read the control registers. At their active states, the signals serve as an output control signal. During the DMA transfer, the signal from line B13 controls the loading of data into the peripheral device. When line B14 reaches the active low state, the DMA controller uses the signal to access data from a peripheral device during the direct memory-access write transfer operation.

After either the memory or I/O

address-enable occurs, the processor addresses the memory and I/O devices with active high levels on lines A12 through A31. These twenty address lines provide access to approximately one million memory address locations. Consecutively numbered down from the most significant bit to the least significant bit, address line A12 carries address bit 19. Address line A31 carries address bit zero. Typically, the DMA controller generates address bits zero through seven and the processor generates address bits eight through 19. As the processor generates addresses, the bus controller sends the address latch-enable signal through line B28. Primarily, this signal latches valid addresses from the processor, but it also acts as another indicator. Acting in series with the address enable signal from line A11, the address latch enable signal shows the I/O channel that a valid processor address exists.

Three lines remain in the description of backplane signal lines. Working at an active high level, the reset drive signal at line B2 monitors the system logic. As the microcomputer goes through power-up, the reset drive signal initializes the system logic, synchronizing to the falling edge of the system clock signal. Similarly, if the reset drive signal senses a low power supply condition, it resets the system logic in the same manner. Lines B20 and B30 carry clock and oscillator signals. As line B20 carries the 4.77MHz signal of the system clock, the 14.31818MHz clock signal flows through line B30. When we examine the actual CPU card, we will also take a closer look at the two clock signals.

Essentially, a detailed look at the backplane architecture gives the technician an idea of what happens during the microcomputer system operation. Although the operation detailed in the backplane description occurs within an instant, the technician needs to recognize the action of the various signals. For the technician, a logical troubleshooting procedure depends on a sound knowledge of circuit action. If you look at the troubleshooting flow chart, the need for that knowledge becomes readily apparent. In future articles of this series, we will discuss the individual functions of each card and the peripheral devices of the Zenith microcomputer. Not surprisingly, as we look at the cards, we will also find ourselves continually referring to the backplane signal operation. ■

# Implementing an electrostatic discharge awareness program

You walk across the carpeted room, reach for a door knob and — Zap! — you find yourself on the receiving end of a tiny shock. Nothing particularly extraordinary about that. Those little shocks can happen any time and almost anywhere. But in the electronics world they become a far more serious affair because they are a threat to sensitive electronics components.

That's why the U.S. military is concerned about it. Information provided by the Office of Public Affairs at Warner Robins Air Logistics Center at Robins Air Force Base, GA, said that the Directorate of Maintenance's Airborne Electronics Division is stepping up its efforts to control the hazard known as electrostatic discharge (ESD). Its concept, which combines formal ESD training with awareness and protective measures, is expected to lead to a long-term, comprehensive program to safeguard the vast majority of components in the avionics center. The plans are detailed, right down to the type of floor wax that will be used. Some of the details of that program are presented here. Adapted by consumer electronics servicing facilities, these measures could reduce damage to ESD-sensitive components and products.

## The ESD problem

Static electricity is generated whenever two substances are rubbed together and then separated, or whenever they flow relative to one another, such as when a gas or liquid flows over a solid. The static electricity is stored on non-conductive materials and tends to remain in the localized area of contact, awaiting the opportunity to discharge to the first available ground source.

Many of today's electronic components are susceptible to some degree of damage from electrostatic discharge of 100V or less, and numbers of such static-sensitive components will continue to grow. On a dry day at 15% relative humidity, no

activity can be performed, not even the simple act of raising your arm, that will not generate more than 100V.

The construction and design features of modern electronics technology have reduced the size of the components to greatly miniaturized dimensions over all previous technologies. This microminiaturization is increasing the susceptibility of components to damage by ESD.

Microminiaturization has resulted in parts that can be destroyed or damaged by ESD voltages as low as 20V. A person can detect a static electric shock only at voltages above 4,000V.

Most ESD damage occurs below the human detection level, and the damage it does is often invisible under the microscope. Sophisticated analysis is required to detect ESD failures, and some do not become apparent until some time has elapsed. These so-called latent ESD failures are malfunctions that occur because of earlier ESD exposure that did not result in an immediate detectable failure.

In short, ESD is a serious problem that calls for serious solutions.

## All components are static sensitive

Much of the electronics industry has

been treating all of its parts as ESD-sensitive because it is more economical and easier to handle all the parts the same way. Warner Robins ALC will start treating all ESD-sensitive components and its related printed circuits as ESD-sensitive. This new management concept is a *total ESD environment*.

It's an *ounce of prevention is worth a pound of cure* approach that focuses on cost-effective ways to enhance reliability and maintainability.

## Training is the key

The division started its program with training, which is offered in two levels. Twenty-five people assigned to the electronic warfare area already have received the formal 3-hour training course, the first level. An estimated 1,700 production and software workers will receive the first-level training.

Second-level training is a videotaped presentation for management and support staff who do not work on the equipment directly, but who still occasionally come in contact with ESD-sensitive devices. Long-range plans call for the development of a 40-hour course.

Employees completing the training will receive special decals. The decals of first-level trainees will authorize them

Table 1.  
Component static susceptibility

Type	Typical susceptibility level
MOSFET	100V to 200V
JFET	140V to 10,000V
CMOS	250V to 2,000V
Schottky diode	300V to 2500V
Polar transistor	380V to 750V
ECL	500V
SCR	680V to 10,000V

Adapted from a paper by the U.S. Air Force.

## Understanding static

A static charge is the result of an excess or deficiency of electrons on a surface. The relative amount of electron imbalance determines the static charge level. Simply stated, a charge is generated by physical contact between, then separation of, two materials. One surface loses electrons to the other.

The types of materials involved and the speed and duration of motion between them determine the charge level. Common non-conductive plastic packaging materials such as polyethylene, polystyrene or mylar films are particularly prone to this electron imbalance.

Even relatively low levels of static electricity can destroy or degrade certain electronic components. Sensitive devices include metal oxide semiconductor (MOS) devices, junction field-effect transistors (JFETs), diodes, thick-film resistors and various bipolar circuit elements. The typical ranges of static susceptibility for

such devices are listed in Table 1.

These kinds of devices are manufactured with multiple oxide layers with tolerances measured in millionths of an inch, and they are designed to operate at low voltage levels. Static electricity can create shorts, opens or changes in critical performance values, and the damage may not surface unless the device is called on to operate at or near its rated load.

An electrostatic discharge event that occurs during the handling of a device is the most obvious form of damage. However, many devices can be ruined or degraded without direct contact or noticeable spark. The key is to protect a component at all times from static charge and voltage fields exceeding its rated breakdown voltage.

Reprinted from the article "Static Control, A Continuous Concern," by Mike Voss of the 3M Static and Electronic Control Division, Austin, TX, published in the May 1988 issue of *MSM* magazine.

to work in areas with ESD-sensitive items. Second-level trainees receive decals that give them access to such areas, but not authorization to work on ESD-sensitive items.

### Keep untrained technicians away

Another part of the plan is to establish ESD zones, identified with dots or lines, where sensitive components are handled. Only certified employees will have access. A prototype is being set up in one production area, and lessons learned there will be applied as the zoning concept is developed elsewhere in the avionics complex.

Also, standardized storage and packaging procedures will be used to protect items against ESD buildup when they are not being worked on.

The ESD plan uses an approach to ensure that all program elements are integrated as a system and to reduce the ESD hazards throughout the facility, especially where ESD-sensitive items are handled outside of their protective wrappings. The plan considers existing equipment and facilities and how they can be effectively converted consistent with the

# Tucson

August 7-12, 1989

## 1989 National Professional Electronics Convention and Professional Electronics Trade Show

- For Consumer Service Dealers and Technicians
- Management and Business Seminars
- Technical Seminars and Certification
- Meetings with Major Manufacturers' Reps
- Trade Show and Association Meetings
- Instructors Conference
- Sponsored by the National Electronics Sales & Service Dealers Assn. and the International Society of Certified Electronics Technicians
- Special room and transportation rates provided by Loews Ventana Canyon Resort, Tucson AZ



For more information, call or write to NPEC '89, 2703 West Berry Street, Fort Worth, TX 76109; (817) 921-9061.

Name \_\_\_\_\_  
 Address \_\_\_\_\_  
 City \_\_\_\_\_ State \_\_\_\_\_ Zip \_\_\_\_\_  
 Phone \_\_\_\_\_

## ESD PRODUCTS FOR SERVICE TECHS

**FREE**  
Award Winning  
Catalog

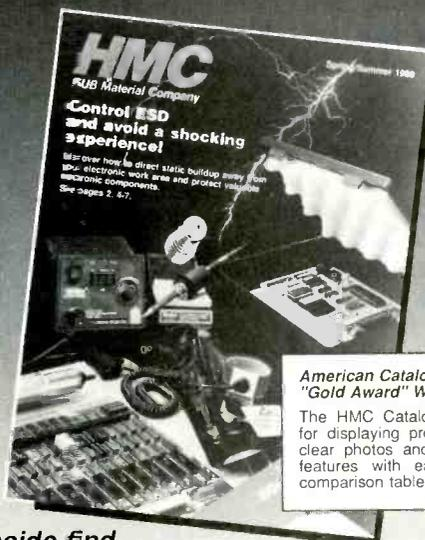

American Catalog Awards  
"Gold Award" Winner

The HMC Catalog — recognized for displaying products with large clear photos and describing their features with easy-to-understand comparison tables & concise copy.

### Inside Find...

Conductive & Static-Shielding Bags • Wrist Straps • Ionizers  
 Table & Floor Mats • Conductive Foam • Topical Antistats  
 Grounding Kits & Devices • Conductive Bins & Tote Boxes  
 Static Meters • Static Awareness Labels • PCB Carriers

Send for your **FREE** copy today!

**HMC** 33 Springdale Avenue, Canton, MA 02021  
 Circle (12) on Reply Card

ESD control requirements for the sensitivity of the items involved.

One of the most important aspects of the ESD plan is education. The most elaborate ESD prevention and handling procedure will not provide the protection needed if personnel are not properly trained in their correct use.

Employees are being trained to effectively use materials and equipment and to understand the theory behind many of the ESD procedures. The most important part of the ESD plan is to inspire a greater sense of awareness and responsibility toward ESD damage prevention.

### Protecting static-sensitive equipment

Much has already been done to prevent ESD damage. For example, items slated for repair are inspected for ESD sensitivity before they are routed to the production areas.

ESD-sensitive devices are typically packaged in two bags. An inner bag of antistatic polyethylene material prevents static buildup. The bag is impregnated with a soapy material that provides a "sweat" layer on the outside of the bag. The outer bag has a thin layer of metal that prevents static from going through the bag.

Electronic components are placed on a table equipped with ESD-protective devices. A conductive mat dissipates static. Production workers wear wrist straps that connect by wire to a ground. Resistors between the straps and ground prevents the possibility of shock. The grounds, which in the avionics center are water pipes or air lines, have to be at a certain depth to be effective.

Plastics are hazardous to ESD-sensitive items because plastic is a purely non-conductive material that can be charged with the slightest friction, heat or pressure. Common items, such as plastic cups and tape, will be removed from ESD-sensitive zones when the full plan is implemented.

Plastics commonly found on tool handles can be used if they are treated with antistatic spray. Such sprays and conditioning foams also figure in the overall control plan.

A program such as the one used in the Air Force avionics installation is extremely important because it's possible that they might affect people in a life-threatening situation. It's not as critical in the servicing of consumer electronics products, but it's important, nevertheless, because it could prevent needless, costly damage. ■

## Products

### Digital video probe

The DP-100 digital video probe from *Tektronix* gives the user an analog view of digital data. The user can tap into a data bus, convert the signal to analog and display it on a scope, waveform or picture monitor or a vectorscope. Features include a fully buffered ECL/TTL probe, up to 50MS/s data rates, a precision 10-bit DAC, a switchable reconstruction filter, and adjustable clock phasing and sync timing.

Circle (76) on Reply Card

### Roll pouch kit

The RP3926 39-piece lab roll pouch kit from *Contact East* includes an assortment of pliers, cutters and fastening tools to access and maintain a variety of equipment. The kit features a set of professional soldering tools and a voltage tester screwdriver that detects the presence of voltages from 80Vac to 330Vac.

Circle (77) on Reply Card

### Waveform monitor/vectorscope

The model 5872 combination waveform monitor/vectorscope from *Leader Instruments* offers simultaneous vector and waveform display for observation of two video sources on the same screen. Features include sweep rates of



1H, 2H, 1V, 2V and 1H MAG, 2H MAG, 1V MAG and 2V MAG; a  $\times 5$  vertical gain magnifier; chroma and IRE filters that can be inserted on a full-time or line-shared basis; and a switching mode power supply.

Circle (78) on Reply Card

### BNC connector adapter kit

The model 5511 BNC connector adapter kit from *Pomona Electronics* consists of six variations of BNC male/female connector adapters. The

case interior is fitted with a contoured foam liner to separate and protect the metal adapters.

Circle (79) on Reply Card

### Aerosol product line

The Cramolin aerosol product line from *Caig Laboratories* uses only ozone-safe propellants. The fast-acting, de-oxidizing solution cleans, preserves and lubricates metal surfaces, including gold. The solution maintains maximum electrical conductivity to prevent contamination.

Circle (80) on Reply Card

### Memory chip tester adapter

The RAMCHECK 1Mbyte adapter for the RAMCHECK memory chip tester, manufactured by *Aristo Computers*, can test 1Mbyte, 256K by 4 and 64K by 4 chips in addition to the standard 256K and 64K chips. A bad chip or the correct chip type is identified on the RAMCHECK display. Existing owners get a free EPROM upgrade that provides an improvement in error-detection rate for the standard 256K and 64K chips.

Circle (81) on Reply Card

### Cleaning/polishing/burnishing kit

The All Kit from *The Eraser Company* contains a selection of Rush Industrial cleaning, polishing and burnishing brushes. The kit contains different sized stick brushes in coarse- and fine-grade FybRglass; a set of refillable, pen-type brushes; nylon, brass and stainless steel refills; a rotary polishing wheel; palm-held and rotary brushes; two metal, refillable brushes; two small abrasers; and a utility brush for cleaning hard-to-reach areas. All can be used on metallic and non-metallic surfaces.

Circle (82) on Reply Card

### Analyzer

The LC102 Z-Meter capacitor and inductor analyzer from *Sencore* tests capacitor values from 1pF to 20F by charging the capacitor through a precision resistor, measuring its time constant and displaying the value on the digital LCD readout. Capacitor leakage is dynamically tested at the operating voltage. When the test is completed, the capacitor is safely discharged. Inductors are also tested dynamically, in or out of circuit, from 1 $\mu$ H to 20H. Features in-

clude a dielectric absorption test, an ESR test and a ringing test. The meter compares results to EIA standards and displays a good or bad indication.

Circle (83) on Reply Card

### Color pattern generator

The Philips PM 5518 TXI color pattern generator, available from *John Fluke Mfg.*, offers full remote control through a standard GPIB/IEEE-488 interface for use in automated testing systems. This generator covers TV standards NTSC, PAL and SECAM, as well as PAL N and M standards. The unit features composite video outputs, sound



modulation in dual channel and mono, and special test patterns, including a 250kHz multiburst, a VCR pattern and a demodulation pattern. All available TV and sound modulation can be selected remotely. More than 70 test patterns and carrier frequencies between 32MHz and 900MHz can be selected by direct entry at the numeric keyboard or over the GPIB/IEEE-488 interface.

Circle (84) on Reply Card

### Digital multimeter

The DM310 digital multimeter from *Universal Enterprises* has a 3½-digit LCD digital display with ½-inch-high numerals. The meter features overrange and low-battery indication, an audible continuity buzzer, 33 ranges, a data-hold button, auto polarity, diode and transistor check function, and a 10MΩ input impedance on ac and dc voltage ranges. The ruggedized meter can withstand a 7.5-foot drop and offers safety features such as surge voltage protection, resistance and buzzer circuits protected to 250Vac, and fuse protection on all current ranges except 10A.

Circle (85) on Reply Card

### Digital sampling scope

The PCIP-SCOPE from *MeiraBytes* is a 20MHz digital sampling oscilloscope that provides dual-channel operation, 8-bit vertical resolution and

full input protection. Both channels provide ac and dc input capability. Input signal bandwidth is 10MHz, and the maximum real-time sampling rate is 20MHz, which yields a 50ns sample period. Effective sampling rates can reach as high as 500MHz. The scope features simple programming, 5mV to 5V input sensitivity, and free software with pop-up control menu.

Circle (86) on Reply Card

### DMM

The SOAR model 3060 DMM, developed by *Carlo Gavazzi Instruments*, incorporates a 3,200-count, full-scale analog bar graph, high-speed auto or manual ranging, a diode test, a continuity beeper function, and speed sampling of the 32-segment bar graph display. The DMM is fully protected on all ranges to 450V. It uses dual-slope integration for measuring ac and dc voltages to 450V and resistances from 300Ω to 30MΩ.

Circle (87) on Reply Card

### Digital decade substituters

The IET portable substitution boxes, available from *HMC*, are used to set resistance, capacitance and inductance values. The desired value can be dialed in with side-by-side thumbwheel switches, which are colored according to the various impedance ranges. The impedance values are preset and read directly to avoid mistakes. Four series of substitution boxes are available: RS series sets resistance; CS series sets capacitance; RCS series sets both resistance and capacitance; and the LS series sets inductance. The units are also available in precision models.

Circle (88) on Reply Card

### Circuit tester

*Vortec* has developed a compressed-air-powered circuit tester that uses -20° air to chill circuit boards, sensors and electronic components. The model 138 circuit tester cools sensors and components in five to 10 seconds with a stream of cold air that leaves no residue. The cold air outlet is sized to permit targeting of tiny electronic components and circuits. An integral muffler to exhaust the hot air and an insulated housing allows the unit to never become hot or cold to the touch. Each unit has no moving parts to wear out or maintain

and comes with a filter, regulator and six inches of airline.

Circle (89) on Reply Card

### Soldering station

The model 7050 temperature-controlled soldering station from *Endeco* offers the convenience and safety of temperature control for users who do not need to meet MIL standards. The unit maintains temperatures with an on/off controller and features a standard three-wire grounded iron with a temperature range of 450°F to 950°F.

Circle (90) on Reply Card

### Screwdriver

The PA 1955 screwdriver from *Paladin* has six bits (two Phillips, two slotted and two hex). The driver design allows the user to unscrew the handle cap and select the proper bit, which is stored in the handle when not in use. The ergonomic handle is formed to fit the user's hand to generate more torque. Each handle is injection molded on the shaft during the assembly process to eliminate breakage. *Paladin* offers a guarantee against breakage on the screwdriver shaft.

Circle (91) on Reply Card

### Oscilloscopes

*Beckman Industrial* has introduced three oscilloscopes: the model 9102 (20MHz), model 9104 (40MHz) and model 9016 (60MHz). The scopes are equipped with trigger circuitry that ensures display stability. A variable hold-off control ensures proper triggering on

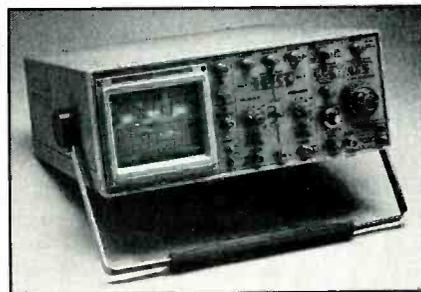

complex signals. Each model features A and B sweeps with delay and segment magnification; TV sync coupling for easy video service; a camera-mount CRT bezel, variable scale illumination and single sweep operation for waveform photography; and Z-axis input for blanking or intensified markers.

Circle (92) on Reply Card

Sears 564.49010250, 564.49020250-251, 564.49060350-351 1  
Photofact 2177-2

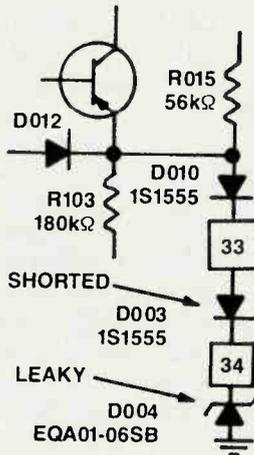

**Symptom:** Shutdown/no voltage regulation.  
**Cure:** Replace shorted D003, leaky D004.

Sears 564.42101151 4  
Photofact 2100-2

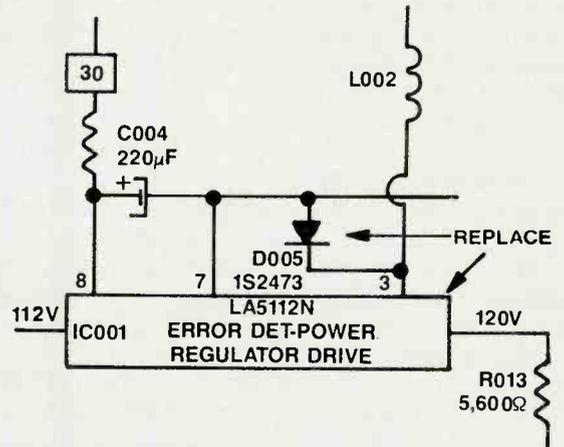

**Symptom:** No voltage regulation, shutdown.  
**Cure:** Replace LA5112N and D005 (SK9188, Sears 46-13428-3).

Sears 564.49010250 2  
Photofact 2177-2

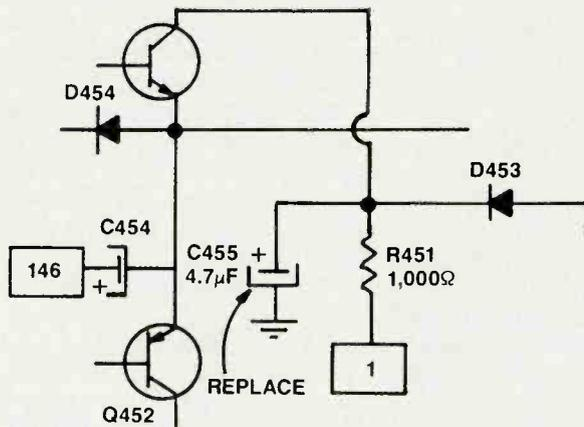

**Symptom:** Foldover and loss of vertical deflection at top of picture.  
**Cure:** Replace C455, 4.7μF capacitor.

Sears 564.42101151 5  
Photofact 2100-2

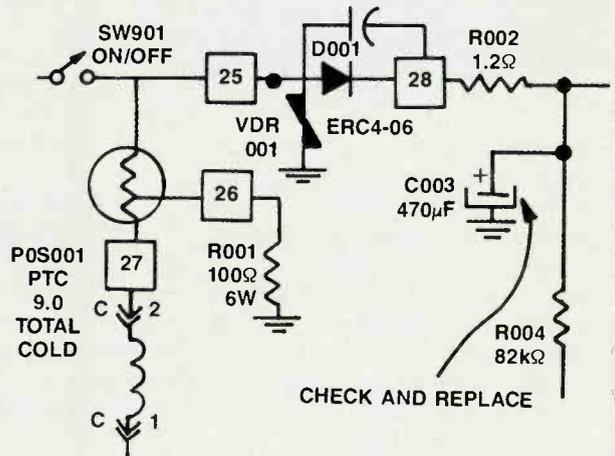

**Symptom:** Low dc voltage.  
**Cure:** Check and replace C003 if it has reduced capacity.

Sears 564.49010250 3  
Photofact 2177-2

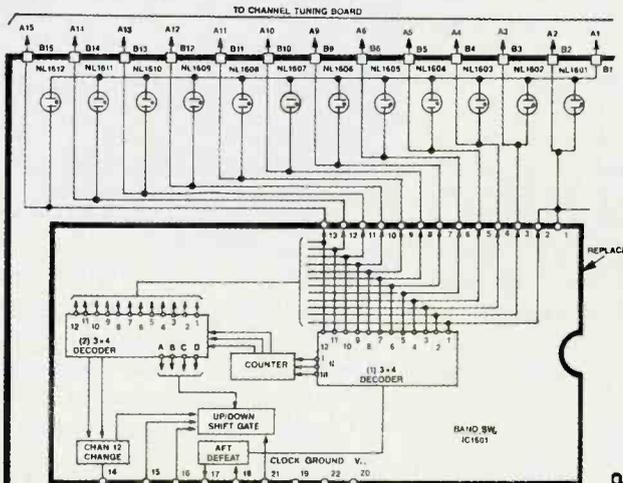

**Symptom:** Will not change channels, but will tune.  
**Cure:** Replace M51233P.

Sears 564.42072050, 564.42230050 6  
Photofact 1990-1

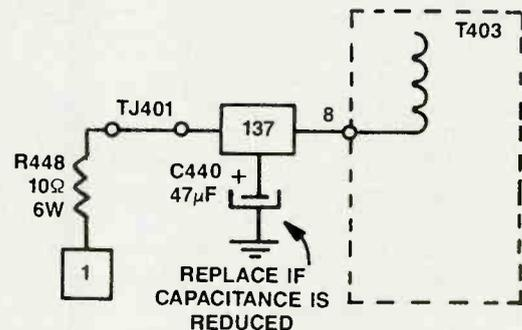

**Symptom:** Picture is half width.  
**Cure:** Check C440 for lost capacity.

## Books/Photofact

**Customize Your Home Entertainment System: TV and VCR Enhancement Projects**, by Steve Sokolowski; TAB Books; 288 pages; \$15.60 paperback, \$24.95 hardbound.

The inexpensive projects in this book allow the reader to have a custom entertainment system with improved sound and video. The book also includes a mini-course in basic electronics, emphasizing development of project-building skills. Enhancements included are noise-reduction systems, graphic equalizers, surround-sound decoders, stereo simulators, a stereo audio control, an audio power meter and a bass boost filter.

TAB Books, Blue Ridge Summit, PA 17294-0850; 800-822-8138.

**Radio Operator's License Question & Answer Manual, 11th edition**, by Milton Kaufman; Hayden Books; 550 pages; \$19.95.

This manual is a resource for anyone trying to pass the FCC General Radiotelephone License Exam, Marine Radio

Permit Exam or private industry electronics certification exams. The book uses a question-and-answer format, emphasizing solid-state circuitry and state-of-the-art radio communications.

Hayden Books, a division of Howard W. Sams, 4300 W. 62nd St., Indianapolis, IN 46268; 317-298-5604.

**Encyclopedia of Electronic Circuits, volume 2**, by Rudolf F. Graf; TAB Books; 744 pages; \$29.45 paperback, \$60 hardbound.

This second volume of practical circuits includes all new circuit designs, including temperature controls, oscilloscope circuits, probes, stereo balance circuits, buffers, crystal and RF oscillators, pulse generators and more. An index lists the 728 circuits presented in this volume along with the 1,300 circuits presented in volume 1.

TAB Books, Blue Ridge Summit, PA 17294-0850; 800-822-8138.

**Principles of Digital Audio, second edition**, by Ken C. Pohlmann; Howard W. Sams; 432 pages; \$29.95.

This revised edition gives the reader

a comprehensive look at digital audio, complete with technologies such as CD-I, CD-V and DAT. The book begins with the fundamentals of numbers, sampling and quantizing, and covers topics such as digital audio recording and reproduction, alternative digitization methods, error correction, optical storage and transmission, and the compact disc.

Howard W. Sams, 4300 W. 62nd St., Indianapolis, IN 46268; 317-298-5604.

**Understanding Electronics, third edition**, by R.H. Warring, edited by G. Randy Slone; TAB Books; 230 pages; \$11.60 paperback, \$18.95 hardbound.

This basic guide to electronics is an updated edition with redrawn circuit diagrams; a glossary of commonly used electronic equations; and expanded coverage of industrial automation, digital computers and microprocessors, transistors and high-voltage power supplies. The 51 circuit projects from earlier editions are also included.

TAB Books, Blue Ridge Summit, PA 17294-0850; 800-822-8138.

### CUSTOM TOOL KITS FROM TOOL KIT SPECIALISTS

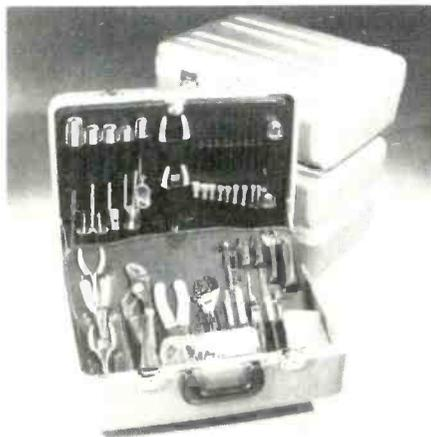

**TKS customizing makes us special.**

- Highest quality tools, cases and test equipment.
- Custom design at no extra charge.
- Kits for field service, technicians, assemblers, or hobbyists.
- TKS expertise and service.

Call for catalog  
(800) 621-0854 Ext. 202

Inside California  
call (408) 745-6020



**TOOL KIT SPECIALISTS INC.**  
1366 Borregas Avenue  
Sunnyvale, CA 94089

Circle (13) on Reply Card

## Presenting an affordable Light Box System.

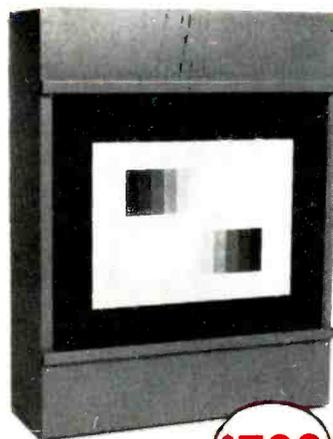

**\$799**

The method most  
manufacturers recommend

Model TR100 CB  
Camera Light Box  
with (2) transparencies

- (2) 3200° Kelvin Lamps (meets mfr. spec.)
- 1-year conditional guarantee
- Transparencies mounted in acrylic with optical scratch-resistant surface
- 11-step gray scale transparency
- 7-Bar color transparency
- All orders are shipped within 72 hours, U.P.S.

**NOTRONIX (313) 939-2740**

P.O. Box 77103 • Sterling Hts., MI 48077



Circle (14) on Reply Card

# Setting a fair price

By William J. Lynott

It's no secret that some electronics servicers have come up against hard times. The increased reliability of today's technology and falling prices for new electronics products have combined to put the squeeze on many service dealers, especially those who aren't doing a good job of diversifying and marketing.

Unfortunately, too many servicers feel that the solution to this problem is to lower their service rates or maintain rates that are already too low. Some dealers feel that it's only an "ivory tower" theory to suggest that most customers will gladly pay the going rate

variations. They are the result of my having worked as a consultant for dozens of service organizations, large and small, over a period of many years.

## Aim for the average customer

In my first job as a TV service technician many years ago, the company I worked for charged \$3.95 for a home service call. That's right, \$3.95! And I can assure you that complaints about service rates were every bit as prevalent then as they are today. That's just the way it is in the service business. People do not like paying for intangibles, regardless of the price.

As often as not, those same people are the sort of customers whose business you are better off without — customers whose business seldom yields a reasonable profit for anyone.

At the other end of the scale is that small percentage of customers who give price hardly more than a passing glance. Getting the best of everything — or at least appearing to — is what is most important to them. It is these people who make it possible for the "premium" labor-rate dealers to exist. I know a number of such dealers and, although my own preferences tend toward a more moderate approach, they seem to have no trouble finding customers.

It is in between these two extremes that you will find the overwhelming majority of all potential customers. These are the people who are willing to pay a reasonable price for what they buy, provided they feel they are getting value and satisfaction for their money. These are the people who represent a secure financial base for the competent and honest service dealer. These are the people for whom both your pricing structure and your policies with regard to customer satisfaction should be fashioned.

## Is it the price or the quality?

It has long been established by industry surveys that most customers' complaints that appear to be centered on the price actually have their roots in the customers' unhappiness with the quality of the product or service that was provided. In other words, many complaints that seem to be about price would never have been born if the customer had been given the satisfaction to which he or she was entitled.

These are just a few of the reasons that I feel the way I do about service rates. The service dealer who attempts to get by on labor rates that are anything less than he is entitled to, or who engages in misleading practices in expressing labor rates, is not only doing himself an obvious disservice, but he is also undermining the fiscal health of his business. ■

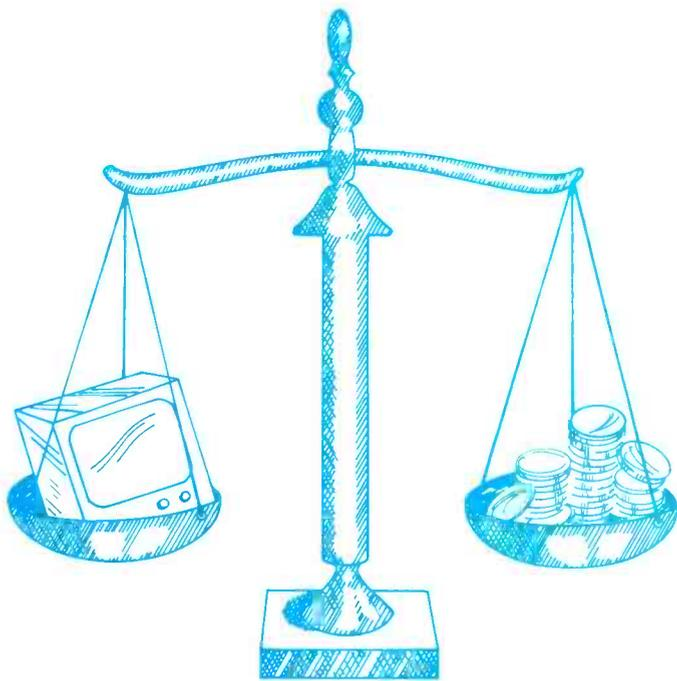

as long as they feel they are getting prompt, professional service.

As a result, some dealers have convinced themselves that they must manipulate their bills in order to hide their true labor rates, or scrape by on rates that are too low to generate a decent profit. If you are among those who feel that way, consider these few obser-

There is, of course, a small percentage of people who will unrelentingly pursue the cheapest price in town for anything they buy, without regard for any other considerations. These people are out there, no denying that, but it's important to remember that they are but a tiny percentage of your potential customer list. To allow one of your most important business policies to be influenced by such a small minority is simply not a sound business decision.

Lynott is president of W.J. Lynott, Associates, a management consulting firm specializing in profitable service management and customer satisfaction research.

# Literature

## Test instrumentation catalog

RAG Electronics is offering a 12-page guide to new and used electronic test instrumentation. The used equipment section features spectrum analyzers, ac and dc power sources, environmental chambers, signal sources and oscilloscopes from Tektronix, Hewlett Packard, Wavetek and others. The new equipment section features selected products from Fluke, Hitachi, Power Designs, PowerVar and more.

Circle (136) on Reply Card

## PC catalog

The 68-page "Personal Computer Instrumentation Catalog" from Rapid Systems shows the company's complete line of turnkey instruments, including oscilloscopes to 100MHz, real-time FFT spectrum analyzers, signal processing systems, universal 100MHz counters, waveform recorders, educational courses and more.

Circle (137) on Reply Card

## Workstation service catalog

Jensen's 32-page "Workstation Serv-

ice Catalog" offers products for troubleshooting, service and repair of data processing equipment. The catalog includes information on the company's workstation tool kits, diagnostic software, tools and test equipment.

Circle (138) on Reply Card

## DMM selector guide

Beckman Industrial is offering an illustrated selector guide describing the company's line of heavy-duty digital multimeters. The guide covers the HD150 Series, a line of 3½-digit, heavy-duty, autoranging DMMs.

Circle (139) on Reply Card

## Watch battery guide

Batt-Tronic has published a comprehensive watch-battery interchangeability guide that lists more than 1,000 battery numbers from more than 20 manufacturers in alphabetical and numerical order. Each battery number is cross-referenced to the proper Batt-Tronic drawer number. The drawer number system guarantees that any battery in the designated drawer is inter-

changeable regardless of the manufacturer.

Circle (140) on Reply Card

## Test equipment catalog

A 32-page catalog of electronic testing and prototyping equipment is now available from Global Specialties. Included in the spring catalog is the company's line of breadboarding products, logic test equipment, power supplies, test instruments and accessories. Also featured is a new line of data communications equipment.

Circle (141) on Reply Card

## Parts catalog

MCM Electronics is offering its 176-page catalog containing more than 11,000 parts and components, including more than 500 new items. Among the categories of products offered are semiconductors, TV parts, computer equipment, power centers and regulators, telephone parts and accessories, connectors, tools, batteries, speakers, VCR parts and audio parts.

Circle (142) on Reply Card

## THE BEST DEGAUSSER FOR CRTS



Lightweight, handy, easy to operate. This is a most effective demagnetizer for video screens, computer monitors, measuring tools, dies, toolbits, cutting tools, etc. Correlative magnetic flux generation: 6.3V. Consumption: 3.3A. Continuous Service Hr: 2.5 Minutes. Weight: 1 Lb. Size: 1.25" x 1.24" x 8".

Send for your FREE Catalog today.

**TECHNI-TOOL** Inc.

5 Apollo Road, P.O. Box 368  
Plymouth Meeting, PA 19462 U.S.A.  
(215) 825-4990 Telex 83-4763  
Fax. No. 215-828-5623

Circle (15) on Reply Card

**"YOU NAME THE REPAIR APPLICATION —  
WE HAVE THE SOLUTION TO YOUR PROBLEM!"**

## MODEL PRS-475 PORTABLE REWORK SYSTEM

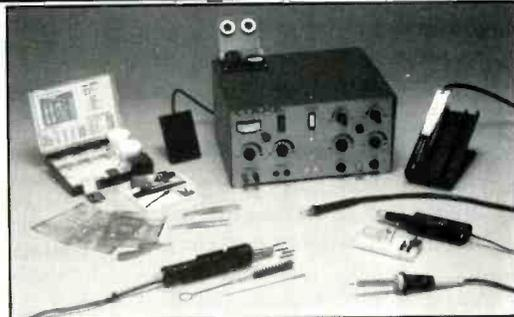

*The Ideal Repair System For Multi-layer PCB Assemblies*

To ensure High Reliability, Repair, Quality and Consistency, Our PRS-475 station has the following new features:

- ✓ Zero voltage switching and localized grounding for CMOS safety.
- ✓ Low voltage heating elements and accessories for operator's safety.
- ✓ Microprocessor controlled temperature regulation.
- ✓ Self contained "instance rise" pump produces the highest vacuum force of 24-26" Hg.

Call Your Local A.P.E. Representative Nationwide To Arrange For An In-House Product Demonstration.

DEPEND  
ON

**A.P.E.**



Automated Production Equipment Corporation  
142 Peconic Avenue, Medford, N.Y. 11763, U.S.A.  
516-654-1197 • TWX: 510-228-2120

Circle (16) on Reply Card

# Troubleshooting problems in the de-emphasis circuit – Part I

One of the less well-understood audio circuits is the de-emphasis circuit. Pre-emphasis of higher frequencies at the broadcasting location, accompanied by equal but opposite de-emphasis at the receiver, results in a reduction of noise in FM radio and TV audio. As with any other circuit in an audio system, the de-emphasis circuits can develop faults.

A fault in an audio de-emphasis circuit could manifest itself as abnormally high audio noise levels or, in the case of a complete failure of the de-emphasis circuit, a tinny sound, as if the treble had been boosted all the way up. Here's a little detail about how pre-emphasis and de-emphasis work, and a suggestion on how to diagnose the de-emphasis circuit if you suspect problems in it.

### The effects of noise

Noise is present in every electronic system. It interferes with the reception and reproduction of wanted signals. Nature generates noise — electrical storms, solar activity and the stars interfere with audio transmission. Human activity also introduces noise because of rapid and random motion of electrons in the molecular structure of electronic components and circuits. These noise sources will limit the performance of any electronic system.

### The effects of noise on FM reception

From the time an RF signal carrier is transmitted to the time it is detected by the receiver, the carrier may be modulated by noise. The largest effect will be in changing the amplitude of the carrier. An indirect effect of noise on the frequency is a small carrier deviation (phase modulation). The limiter stage (before the FM detector) prevents amplitude changes on the carrier from passing to the receiver's detector stage,

which is why FM signals are less affected by noise than are AM signals. Any phase change of the carrier, however, will be passed to the detector and detected as noise.

### Pre-emphasis reduces noise

To minimize these indirect phase modulation effects, the sound level at the output of the FM receiver's detector must be made much larger than the detected noise. The sound volume of an FM detector is proportional to the deviation of the FM carrier. If the audio signals cause a much larger carrier deviation than the indirect noise phase

changes (during transmission and reception) the noise will not be as noticeable. Actually, the larger the modulation index at the transmitter, the better this signal-to-noise (S/N) ratio will be at the output of the FM receiver. In FM broadcasting, the highest audio frequency will produce a maximum modulation index of 5, but for lower audio frequencies it may be much higher. The S/N ratio is proportional to the square of the modulation index. The highest modulation index can increase the S/N ratio by 14dB in FM broadcasting. (See Figure 1.)

### The pre-emphasis network

S/N ratios can be improved by an increase in the amplification of the higher audio frequencies at the transmitter. Amplification will cause larger carrier deviation at those frequencies and thus better S/N ratios at the receiver. The pre-emphasis network at the transmitter increases the amplitude of higher audio frequencies, conforming to a pre-arranged curve, referred to as a 75µs pre-emphasis curve, established by the FCC. (See Figure 2.)

The pre-emphasis network at the transmitter may be a simple RC or LR

MODULATION INDEX	S/N IMPROVEMENT
1	REF.
2	6dB
3	9.5dB
4	12dB
5	14dB

Figure 1. The S/N ratio will improve at the FM receiver in proportion to the square of the modulation index. The modulation index is the carrier deviation divided by the audio modulating frequency.

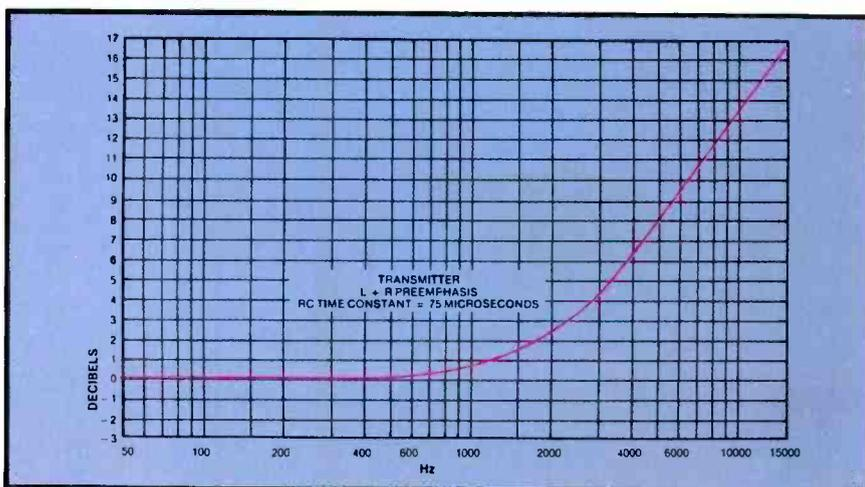
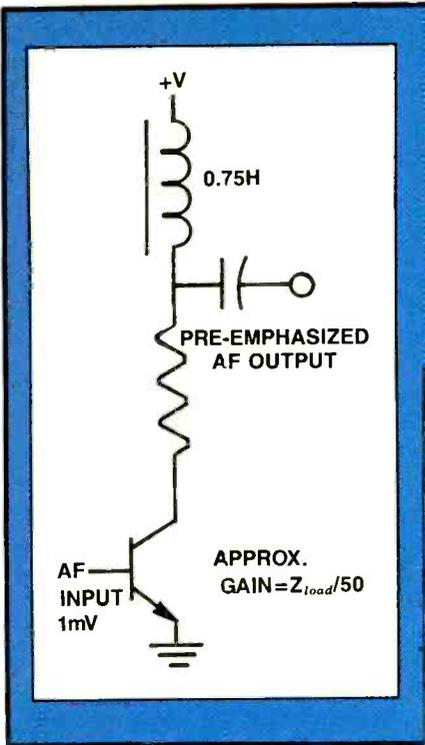

Figure 2. At the transmitter, audio signals are routed through a 75µs pre-emphasis network.

Adapted with permission from Tech Tip #123, "Understanding Pre-emphasis and De-emphasis," published by Sencore, Sioux Falls, SD.



FREQUENCY	TRANSISTOR VOLTAGE GAIN & OUTPUT IN mV	PRE-EMPHASIS GAIN
300	202	0.1dB
1,000	221	0.9dB
2,120	283	3.0dB
3,000	346	4.8dB
5,000	512	8.2dB
8,000	754	11.8dB
10,000	964	13.7dB
15,000	1,428	17.0dB

**Figure 3.** Audio pre-emphasis requires an RL or RC network to increase the amplification of higher audio frequencies to conform to a 75 $\mu$ s pre-emphasis curve.

filter network that will alter the gain of an amplifier to conform to the pre-emphasis curve. The 75 $\mu$ s is the time constant of the network, which will cause a 3dB increase at the frequency given by the formula  $F=R \times C/2$ . This frequency will be about 2,120Hz. Figure 3 shows an example of a pre-emphasis circuit and a chart to indicate how the output impedance of the amplifier

changes the gain of the stage to produce an output that conforms to the 75 $\mu$ s curve.

Next month, we'll conclude this look at pre-emphasis and de-emphasis circuits with a closer look at de-emphasis networks, the location of the networks in the circuitry, and the tests that a servicer should perform to track down problems in these circuits. ■

# Come Out of the Dark.

Each month's "Advance Technology" article is the technical highlight of *Professional Electronics* magazine. P.E. is just one of many "enlightening" benefits available to members of NESDA. For your **FREE REPRINT** of "Trouble-Shooting Procedures for Video Camcorders," and more information about NESDA, just send the following information:

Name \_\_\_\_\_  
 Address \_\_\_\_\_  
 City \_\_\_\_\_ State \_\_\_\_\_  
 Zip \_\_\_\_\_  
 Phone \_\_\_\_\_

National Electronics Sales &

**NESDA**

Service Dealers Association

2708 W. Berry St.  
 Ft. Worth TX 76109  
 (817) 921-9061

\*One of a series.



## 51 Vaco professional hollow-shaft nut drivers fill your exact needs

- Magnetic • Inch • Metric
- Super Long • Kits

All VACO Nut Drivers are loaded with features: full-hollow shafts...nickel chrome exterior...withstand high torque...Comfordome®, color-coded handles. See your VACO distributor.

Send for **FREE CATALOG**

**VACO**®

7200 McCormick Blvd.  
 Chicago, IL 60645

Circle (17) on Reply Card

# IBM personal computer servicing do's and don'ts

By Glenn R. Patsch

Servicing or upgrading a component in a personal computer is much like working on other electronic equipment, except there is both a hardware and a software side to everything. When something is not working properly, it might be the hardware or the software (or both) at fault. As with every other type of electronics equipment, there are some do's and don'ts that will save you a lot of aggravation, wasted time and expense if you follow them when you service personal computers.



**DO** unplug the power cable from the computer chassis and turn off the power switch **BEFORE** opening the cabinet. On rare occasions it may be necessary to check something when the computer is on, but always attempt to fix the problem with the power off first.

**DO** get the key for the PC/AT or PS/2, or you will not be able to get the chassis cover off. It is possible to crack the case to get inside, but it is also expensive to replace. Many users leave the keys in the lock or leave the unit unlocked.

**DO** ask if a password has been set up if it is a PS/2 system. All the PS/2 systems can be set up with a password. If you have the key but not the password, you can disconnect the lithium battery for 20 minutes and the system will no longer require a password. However, you will now have to reset the system configuration, which requires the

Patsch is a consultant specializing in the selection, evaluation and installation of IBM personal computer and compatible hardware and software.

reference diskette and any additional setup disks for cards added. You can usually use the restore configuration option on the reference diskette to reset the setup information that was lost when the battery was removed.

**DO** be aware that in many cases, batteries inside the computer need to be replaced. The PC and PC/XT may have an optional clock on a plug in card. These cards have small button cells that maintain the time and date when the computer is turned off. A few cards have rechargeable nickel/cadmium batteries. The PC/AT has a lithium battery used to maintain the built-in clock and setup information. The PS/2 has a lithium battery used for the clock and setup information. These batteries are rated for one year, but they usually last about two years. The clocks are used to maintain a calendar for dating files that are saved on the system. The setup information tells the system what hardware is present (such as the number of floppy drives and the hard disk size and type).

**DO** get the diagnostic disk that came with the PC and XT. The PS/2 has a reference diskette. Many users will not have this readily available, so you should have your own. You get the advanced version of the diagnostic software with the IBM maintenance manuals. IBM updates these from time to time.

**DO** obtain the diskette the user places in the a: drive for booting the system if the computer you'll be servicing has only floppy disk drives and no hard disk. On hard disk systems, the operating system (DOS) is stored on the hard disk. On a system with no hard disk, the operating system must be stored on a floppy disk. This disk is referred to as the boot disk because it is used to "boot-

up" the system every time it is turned on.

If this disk is not in the a: drive and the floppy door is closed when the PC is turned on, the system will bring up BASIC. This causes no end to confusion if you do not realize what has happened. IBM originally intended to offer low priced systems with no floppy or hard disks and let users bring up the system in BASIC. The idea was to save programs on a cassette tape deck. Older PCs have a connector next to the keyboard connector for this purpose. Depending on what you are installing or changing, you may need to modify files (config.sys and autoexec.bat) on the boot disk.

**DO** be aware that on PCs with a hard disk, if you have a disk in the a: drive when you turn on the system it will attempt to boot off of this disk. This method was intended to give you a way to bypass the hard disk in case it is damaged. If you get a message of "non-system disk or disk error," remove the floppy disk from the a: drive and press any key. The system will try again.

**DO** be aware that when the system is running and you are stuck in a software program, the computer might not respond to anything you do at the keyboard. If this situation occurs, you can press the CTRL, ALT and DEL keys simultaneously and the system will reboot (in most but not all cases). This is known as a *warm boot* and is almost the same as turning off the computer and turning it back on. There are a few situations that will not respond to the warm boot, and the only way to regain control of the computer is to turn it off and then back on with the switch. Always try a warm boot first, however. A warm boot saves some wear and tear

on the computer compared to a cold boot, and it is faster.

Many software programs will also recognize the combination of the CTRL and Break keys and will suspend operation and return you to DOS. This is preferable to the CTRL-ALT-DEL combination because it suspends operation of the currently running program but doesn't reboot the computer. This combination usually doesn't work with problem programs.

**DO** be aware that the PC, PC/XT and PC/AT have DIP switches on the system board that may need to be changed depending on what you are installing. The PS/2 uses software to configure the system.

**DO** be aware that some hardware requires software changes to be made to the system configuration file (config.sys) to be properly used by the system. Some hardware also requires a change to the batch file that executes automatically every time the system is turned on or rebooted (autoexec.bat).

**DO** realize that if you don't understand these guidelines, you need to review PC basics before opening the cover of the computer.

**✓ DON'T**

**DON'T** move a PC with a hard disk unless you are positive that the disk head has been parked with a software utility, or you are absolutely sure that the disk itself has an automatic head-parking feature. If you move the PC and the disk

head was not parked, the head may crash into the magnetic disk surface, damaging it. These surface scratches may cause the disk to lose data. To be safe, the hard disk should be completely backed up using the BACKUP command or a software backup utility that copies the contents of the hard disk to several floppy disks or a tape. The IBM diagnostic diskette for the PC/XT includes a shipdisk command (Shipdisk.com file) for parking the disk head. The IBM PC/AT disks must also be parked. Some of the newer IBM PS/2 systems have drives that automatically park the heads.

**DON'T** disconnect a PC from a network until you properly sign off the network. Ask before doing so or you may cause network problems. Most networks are set up so each PC has a batch file that accesses the network and another that drops access. Just turning off the power switch does not properly sign off some networks. If you see a coax cable attached to the back of a PC, suspect that it is part of a network and consult with the operator before disconnecting it.

**DON'T** be intimidated by personal computers. They are very straightforward. Like everything else, they require some education and a little patience.

These suggestions will get you started and save you some time. As with other digital electronic equipment, the personal computer is sensitive to static electricity. Observe precautions if you are changing memory chips, installing a co-processor chip or adding adapter cards. Some of these components are quite expensive to replace if damaged. Avoid touching the edge connectors on the plug-in adapter cards when installing or removing them. ■

## ATTENTION TECHNICIANS

- ★ JOB OPENINGS
- ★ MONTHLY TECHNICAL TRAINING PROGRAM
- ★ BUSINESS MANAGEMENT TRAINING
- ★ SDC SATELLITE NEWS
- ★ CERTIFICATION
- ★ TECHNICAL SEMINARS

All of this in a nonprofit international association for technicians

FIND OUT MORE:



604 N. Jackson St.  
Greencastle, IN 46135  
1-800-359-6706

## CONSOLIDATED ELECTRONICS

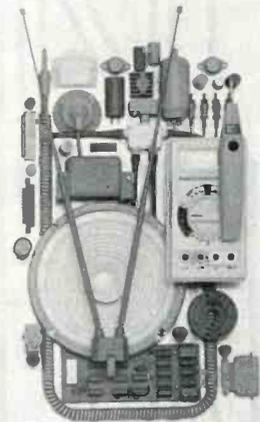

CONSUMER & INDUSTRIAL ELECTRONICS CATALOG • 17TH EDITION

## THE ULTIMATE ELECTRONICS CATALOG.

Order your 260 page catalogue packed with over 10,000 money saving electronic parts and equipment. Send \$3.00 check or money order, or call 1-800-543-3568 today and use your Mastercard or Visa.  
Consolidated Electronics, Incorporated  
705 Watervliet Ave., Dayton, Ohio 45420-2599

NAME	
ADDRESS	
CITY	
STATE	ZIP

Circle (18) on Reply Card

# Using logic in troubleshooting-Part I

By Stewart Leabman

When a technician gets out of school and gets his first electronics servicing job, he often has the tendency to try to memorize different trouble symptoms and their cures. The problem with that method, of course, is the servicer's limited memory.

The best way to approach a servicing problem is to know how different components and circuits work, pinpoint the area most likely to cause the problem, then think your way through the circuit to the problem component. Using logic in your troubleshooting can speed up your repairs by saving you from wholesale desoldering and replacement. Here are a few case histories that illustrate the need to think first and desolder later.

## Noisy hi-fi playback

Following a circuit in a logical manner is important when you are looking for a problem that seems to have no

Leabman is an electronics servicer in Bensalem, PA.

cause. For example, recently a customer brought in a Mitsubishi HS-430UR VCR that was exhibiting noisy hi-fi playback. In this case, the problem was not directly caused by any electronic components. It was caused by a strange signal path that does not exist in theory but did exist in practice.

The VCR had noisy sound in the hi-fi mode. The first thing I did was align the audio-FM switching points with an alignment tape. Although the switching points were slightly off, alignment didn't help.

It sounded like the RF switching points were off, but the hi-fi RF envelope was perfect. Looking at connector HH, pins 12 and 14 on the hi-fi printed circuit board (PCB), I saw that the audio had 30Hz pulses on both channels.

In the right channel, the signal can be traced back through IC3Z7, pin 7, to IC3Z7, pin 3; back to IC3X3, pin 4, to IC3X3, pin 2; back to IC3Z5, pin 6, to IC3Z5, pin 5; back to IC3X4, pin 14,

to IC3X4, pin 17. The signal was good at pin 17, but it had noise pulses starting at the collector of Q3403 after it came out of IC3X4, pin 14. Looking at the base of Q3403, I saw RF switching pulses, but why should there be RF switching pulses there? Tracing back from the base of Q3404 to IC3Z2, pin 7 (see Figure 1), there were the switching pulses at pin 7.

That line is called MUTE. Coming into pin 6 of IC3Z2, RF switching pulses come from connector HX, pin 2. I looked at IC3Z2 from the top of the PCB and found glue on all of the pins. The glue was turning dark brown at the edges, so I wiggled the IC. The noise in the audio disappeared, then reappeared. The glue apparently had become conductive and was shorting pins 6 and 7 of IC3Z2. After I removed the glue, the unit was repaired.

## Dc-dc converter failure

The exact cause of a problem is not always immediately apparent. Again, if you rely on memorizing symptoms and cures, you'll be less able to troubleshoot problems in which the symptoms don't immediately point to a particular problem. This is especially true when the defective part fails because of another not-so-obvious bad part.

In this case, the defective part was overheating and failing because of another bad part. I had been getting quite a few Hitachi/RCA VCRs with the complaint of no display. The reason for the failure has been the same in all of them: There is no output from the dc-dc converter, which supplies several voltages for the clock display and the tuning voltage.

In the Hitachi VT-56, for example, the dc-dc converter is shown as IC1701. (See Figure 2.) In some models, a circuit protector (ICP-N5) is in line with the B+ to the dc-dc converter. In the first unit I saw with this problem, I replaced the dc-dc converter and the set worked

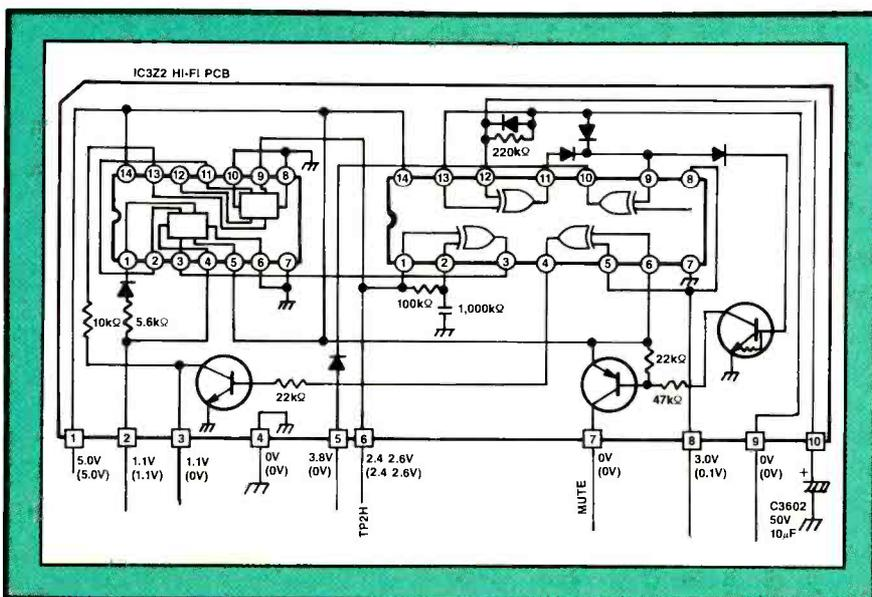
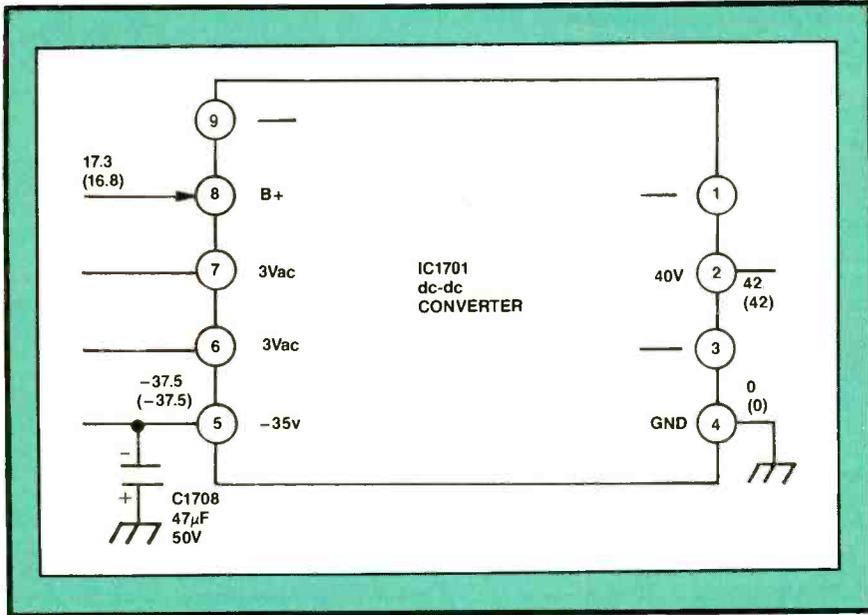

Figure 1. Glue that had become conductive was shorting pins 6 and 7 of IC3Z2, creating an unintended path for RF switching pulses that resulted in noisy hi-fi playback in this Mitsubishi HS-430UR VCR.



**Figure 2.** The dc-dc converter — IC1701 in this Hitachi VT-56 — supplies several voltages for the clock display and the tuning voltage. Open electrolytics, including C1708, can make IC1701 draw too much current.

fine for about 10 minutes. After that time, the display went out and the dc-dc converter was burned up again. I ordered another dc-dc converter, replaced it and measured the current draw. It was drawing about 300mA (too much), which was causing it to heat up.

I disconnected all the loads from the converter, and it still drew 300mA. Wait a minute! What's going on here? I removed the converter from the VCR, hooked up ground and 18V to the B+ input, then measured the current. It was still 300mA and the converter was getting hot. I put the converter back in the VCR, connecting every pin, and measured each pin with my scope. I found that ac was riding on the -35V line, which has C1708, a 47µF capacitor, across it. There should not be any ac there.

I replaced the capacitor, and the converter's current draw dropped considerably. Out of curiosity, I measured the frequency of the converter before

and after I replaced the capacitor and found that it was about 150kHz with the bad capacitor and more than 260kHz with the good capacitor. The problem was the dc-dc converter was running at too low a frequency, causing the excessive current draw in its transformer.

Checking the other electrolytics in the area, I found that they too were bad, no doubt from the heat. I replaced them also and the unit was repaired.

Now, every time I get an RCA/Hitachi VCR with this problem, I find that the same capacitors are bad along with the dc-dc converter. Although I now know the cure to this symptom in this model, knowing how the circuit works helped me avoid a lot of extraneous probing and desoldering. After all, you still have to figure out what the problem is the first time.

Next month, we'll show more examples of how logic in your troubleshooting can help you service VCRs faster. ■

## LEARN VCR

**CLEANING/MAINTENANCE/REPAIR**  
EARN UP TO \$1000 A WEEK, WORKING PART TIME FROM YOUR OWN HOME!



THE MONEYMAKING OPPORTUNITY OF THE 1990's

IF you are able to work with common small hand tools, and are familiar with basic electronics (i.e. able to use voltmeter, understand DC electronics)...

IF you possess average mechanical ability, and have a VCR on which to practice and learn...then we can teach YOU VCR maintenance and repair!

**FACT:** up to 90% of ALL VCR malfunctions are due to simple MECHANICAL or ELECTRO-MECHANICAL breakdowns!

**FACT:** over 77 million VCRs in use today nationwide! Average VCR needs service or repair every 12 to 18 months!

Viejo's 400 PAGE TRAINING MANUAL (over 500 photos and illustrations) and AWARD-WINNING VIDEO TRAINING TAPE reveals the SECRETS of VCR maintenance and repair - "real-world" information that is NOT available elsewhere!

Also includes all the info you'll need regarding the BUSINESS-SIDE of running a successful service operation!

**FREE INFORMATION**

CALL TOLL-FREE 1-800-537-0589  
Or write to: Viejo Publications,  
3540 Wilshire Bl., STE 310  
Los Angeles, CA 90010, Dept. EST

Circle (19) on Reply Card



Your Ticket To

# SUCCESS

Over 25,000 technicians have gained admittance worldwide as certified professionals. Let your ticket start opening doors for you.

IS CET offers Journeyman certification in Consumer Electronics, Industrial, Medical, Communications, MATV, Radar, Computer, and Video. For more information, contact the International Society of Certified Electronics Technicians, 2708 West Berry St., Fort Worth, TX 76109 • (817) 921-9101.

Name \_\_\_\_\_

Address \_\_\_\_\_

City \_\_\_\_\_

State \_\_\_\_\_ Zip \_\_\_\_\_

Send material about IS CET and becoming certified.

Send one "Study Guide for the Associate Level CET Test" Enclosed is \$5 (+ \$1 postage).

# Readers' Exchange

## NOTICE: AS OF THE OCTOBER ISSUE, ES&T WILL CHARGE A SMALL FEE FOR READERS' EXCHANGE ITEMS.

To more efficiently process Readers' Exchange items and assure more timely ad turnaround, the Readers' Exchange department will be turned over to the Classifieds staff as of the October issue. Readers' Exchange items will cost 50 cents per word; Classified ads will continue to cost \$1.65 per word. Readers' Exchange items will continue to cover only Wanted and For Sale items. Specialized heads, such as job opportunities or help wanted, must continue to run in the Classifieds section.

### WANTED

105 Sams Photofact folder sets, various sets #4 to #1190; various radio/TV parts; speakers-capacitors; rod antennas; resistors-wirewound power resistors, transistors, etc.; 300 radio/TV tubes, new in original boxes. *Elmer J. Alderman, Route 2 Box 139, Madison, NC 27025.*

Service and/or schematic of the Gertch FM deviation meter, model DM-1 (this is a battery-operated unit in the bottom portion of the Gertch Hetrodyne model FM-3 frequency meter); the old tube-type Lampkin FM deviation meter, dual-scale, must be reasonable and working. *Robert E. Duncan, 1513 Sixth St., Eureka, CA 95501; 707-442-2794 7 p.m. to 11:30 p.m.*

Sams TV Photofacts #1832 through #2598, will pay a reasonable price. Prefer response from Florida. *Jennings Hanson, 735 Clematis Road, Venice, FL 34293; 813-493-4159 or 813-497-0108.*

Power transformer for a Zenith TV, part number 95-3250, model Fh2511w, chassis 25hc50; schematic with service manual, will copy or buy. *James Gebhardt, 319 Cherry St., Columbia, PA 17512; 717-684-7348 weekdays before 2 p.m. EST, weekends all day.*

Sencore CR70, must be in excellent condition, with all five socket adapters and 39G170 universal adapter. Will pay a reasonable price. *J.J. Newman, 819 Connie Ave., Wheelersburg, OH 45694; 614-574-2385.*

Hitachi V-509 oscilloscope, no substitute, can pay \$600 if excellent. *Marvin O. Lofness, 115 West 20th, Olympia, WA 98501; 206-357-8336.*

Leader oscilloscope LBO 301, working or non-working, in repairable condition. *Mike Shelton, 2708 May Drive, Burlington, NC 27215; 919-227-2908.*

High-voltage transformer for MGA model CS1981 color set, need complete transformer; push-pull output transformers for the Leslie external speakers #101 and #102, were used with the Gulbransen theater organ, could use the whole amplifier if available, uses 8-7189 and 4-12AU7 tubes. *Worth Hitchcock, Tri-City TV, Rt. 3 Box 186, Birch Tree, MO 65438; 314-292-3281.*

On/Off volume control for Quasar chassis CTS-959B01, service WT5812NW. *Jim Bundy,*

*4657 N. Neeley, Decatur, IL 62526; 217-429-2675.*

Horizontal hold oscillator coil, part #2829-003-0105, for a Bohsei model TC-800 color TV (made by Samsung), new or used. Send price. *John Augustine, Augustine's TV/Radio Service, 530 N. Ninth St., Reading, PA 19604; 215-372-5438.*

V-U meter for an AKAI model M-8 reel-to-reel tape recorder. *Paul Jones, 10595 Vista Valle Drive, San Diego, CA 92131.*

Service literature or address where to obtain info on a model 146LBI Playmate organ by Thomas Organ Co. *Willard Weierbach, RRI Box 89, Coopersburg, PA 18036; 215-346-7701.*

Service manual for a Toshiba model V8030T VCR, maybe same as model V5530. Will copy and return or buy. *John Reynolds, 1942 Sandalwood Lane, Fort Collins, CO 80526; 303-484-2715.*

Schematic and instruction manual for Keithley model 130 digital multimeter. Will copy and return or pay for copy. *Gerard O'Gara, 11 Crag Lane, Levittown, NY 11756; 516-731-4075.*

B&K model 606 Dyna Jet and 707 tube testers. *Charles T. Huuh, 229 Melmore St., Tiffin, OH 44883; 419-448-0007.*

PLL/programmer PC board for a Radio Shack Realistic Comp-100 scanner monitor, part number G.E.-21B-5703. *James W. Strickland, 413 Lakewood St., Blytheville, AR 72315; 501-763-4147.*

Schematic (with board layout) for a Readers Digest model RDA-127 radio; schematic for a Philco model 81-121; schematic for a Yorx model K3654 tape player. Must be reasonable. Good photocopy OK. *A. Edward Ruppel, 1207 Adams St., Saginaw, MI 48602.*

Heathkit IM 5258 distortion analyzer; B&K 2040 signal generator: wow and flutter meter. Must be reasonable. *Gil Foley, 6205 N. 59th Ave., Glendale, AZ 85301; 602-937-3241.*

Sams Photofact service manuals; CB radios; auto radios, scanners. *Greg Hingle, Rt. 2, Box 584, Port Sulphur, LA 70083; 504-564-2517.*

### FOR SALE

Sam's with file cabinets, #600 through #1864, \$800. *Mark Oliva, Oliva Audio-visual, Box 742, Milford, NE 68405; 402-761-3344.*

Model VR 9800 (Sony SL 2000) portable Beta video recorder with color camera, excellent condition, \$450 or best offer; Simpson white dot generator, working, \$20; working Philco Predic-ta, best offer; repairable Zenith JR9000 VCR, \$50. *Joe Sanfilippo, Northern Technical SVC, P.O. Box 347-1935 N. Framing Road, Woodruff, WI 54568.*

Tektronix model 2445 portable scope, 150MHz, CRT readout, delayed sweep, quad-trace, two brand-new probes, very good condition, \$1,600 or best offer; Fluke 77 DMM, excellent condition, \$100. *Roberto Duran, 1231 Sherbourne Drive, Los Angeles, CA 90035; 213-272-7289.*

Sencore VA62 Universal Analyzer with VC63 VCR test accessory, \$3,000 (cost \$3,990); Sencore LC75

portable Z-meter 2-capacitor/inductor analyzer, \$750 (cost \$995). Like new, manuals, VA62 videotape, will ship in original cartons. *Rob's Video Services, 3100 S. Georgia, Amarillo, TX 79109; 806-352-6699.*

Eico model HVP-5 HV voltage probe, \$25; Eico model 584 battery tester, \$15; Stancor P-6415 isolation transformer, \$25; 10 years of Sylvania factory service manuals; transistors, chips and factory parts (never used) — send SASE for list. No reasonable offer refused. *Raynham TV, 803 Orchard St., Raynham, MA 02767; 508-824-4269.*

Heathkit color bar generator, \$50; B&K 466 pix tube tester and rejuvenator with adapters, \$175; Knight R/cap. tester, \$30. *M.E. Andrews Jr., Box 91, Exeter, RI 02822.*

Used only once, new Fluke model 87, true rms ac, 4½-digit mode, back-lit display, frequency, capacitance and many other features, \$225 plus shipping. *Stanley Todorow, 8468 Belle Bluff Drive, Grand Blanc, MI 48439; 313-695-0271.*

Sams Photofacts, #250 through #1000, all for \$150. *Jennings Hanson, 735 Clematis Road, Venice, FL 34293; 813-493-4159 or 813-497-0108.*

Sams Photofacts, #1-840 and #1380-2600 (50% between 840 and 1380), \$1,500 plus shipping. *Lee Schantz, Lee's TV Service, 5330 Galena Drive, Colorado Springs, CO 80918; 719-598-0508.*

Sencore VA48, \$475; Powerite PR57, \$350; CR70 Beam Builder, \$900; Heathkit 2240 digital LC bridge, \$150. All in excellent condition, includes manuals, leads and warranties. *Robert Bell, Route 3, Box 400, Toccoa, GA 30577; 404-886-4466.*

EMC model 206 tube tester (circa 1946/1947), brand-new, never used, includes operating manual; RCA model WR89A marker generator and RCA model WR59C sweep generator, includes all schematics and operating instructions; RCA model WV97 Sr. Voltomyst with operating manual and schematic. *Melvin C. Roppelt, 216 Meadowvale Road, Lutherville, MD 21093; 301-825-4874.*

Sencore CA55 capacitor checker, \$175; Heathkit IT5235 yoke and flyback tester, \$125. *Eddie Bryant, 9809 Hilgert Drive, Cleveland, OH 44104; 216-721-9435.*

Magazines from early 1960's to present — PF Reporter, ET/D, ES&T — make offer; 305 new name-brand radio and TV tubes; 105 Sams Photofact folder sets; one set of radio manuals (24 volumes) by Supreme Publications; servicing diagrams 1926-1969; TexFax manuals — volumes 103-115. SASE for a more complete list. *Elmer J. Alderman, Rt. 2, Box 139, Madison, NC 27025.*

Owner relocating — service manuals (Sams, Quasar, Sharp, NAP); test equipment; tubes; parts inventory; merchandise inventory; office equipment; many miscellaneous items; van, building and property. Great hunting and fishing. Building adaptable to many uses. *R.N. Yasko, Fremont TV, 407 E. Main St., Fremont, WI 54940; 414-446-2239.*

Repair shop over-stocked on many parts, modules, manuals, etc., no tubes or junk. Sell or swap. Send

SASE for list. *All-Tech Service*, 22622 Lambert, Suite 303, Lake Forest, CA 92630; 714-951-5502.

Sencore VA62 video analyzer, in box, with cables and manuals, like new, \$1,995 (includes COD shipping). *Charles TV*, C.G. Owens, Rt. 210 and Poplar Lane, Indian head, MD 20640; 301-743-3153.

Millen 90651 grid dip meter, \$50; Gertsch-Singer FM-9 frequency deviation meter, \$325; Sencore FE-20 multimeter, \$25; Bell & Howell model 34 oscilloscope, \$25; Eico 147A signal tracer, \$15. Will consider trades. *Bobby Lee Deck*, 122 Fourth Ave. S., Algood, TN 38501; 615-537-9543.

Gramer Halldorsen 12-inch degaussing coil, \$10; Heath IT 5230 CRT tester with sockets and manual, \$85. Both in perfect condition. *P. Davis*, P.O. Box 615, Manasquan, NJ 08736; 201-502-0961.

Used Drake 240A satellite receivers with down converter, VCII compatible. Excellent working condition. *Little Ocmulgee Service*, P.O. Box 150, Railroad Ave., Alamo, GA 30411; in Georgia, 800-342-1290; outside Georgia, 912-568-1711. Ask for Roger, ext. 218

RETIRING, please send SASE for listing and prices. *Frank N. Sachs*, 6803 Navajo Drive, Baltimore, MD 21209; 301-484-3115.

Sencore SC61 in original shipping box, with manual and cables, \$2,000; Sencore CG25 in original box, \$90. Both in excellent condition. Add shipping. *C. Johnson*, 2384 Shadow Hill, Riverside, CA 92506; 714-684-5583.

Sams 800-1799. Make offer. *Calvin Boddie*, 660 E. Yucca St., Oxnard, CA 93030; 805-486-1071 after 5 p.m..

Sencore SC61, VA62, VC63, in original box with all manuals and cables, \$3995. *Barry Davis*, *Davis Electronics*, Graham School Road, Gallipolis, OH 45631; 304-675-1667.

Hewlett Packard model 410B VTVM, \$95; Hewlett Packard model 130C oscilloscope, 500kHz bandpass, \$195; Tektronix model RM504 oscilloscope, 450kHz bandpass, \$165. Add \$10 for insured UPS shipping. COD OK. *Fred Jones*, 407 Morningbird Court, Niceville, FL 32578; 904-678-1803.

Sams #1 to #2627 (12/88), complete TV set, \$5,000 or best offer. *Mary Rainey*, P.O. Box 160, Concordia, MO 64020; 816-463-2689.

Atari parts and factory service manuals, 2600, 5200, 600, 800, 1200 and more; Mattel factory service manuals and parts. Originally over \$2,000, all for \$750 or best offer. *Bob Brudis*, P.O. Box 9022, Youngstown, OH 44512.

Factory service manuals for VCRs, TVs, cameras, etc.; factory parts. *Bob Brudis*, P.O. Box 9022, Youngstown, OH 44512.

B&K 1077B TV analyst with slides and manual, \$135; Heath model IM18 VTVM with instruction manual, \$35. *Mr. Lurry*, 6738 Amherst St., San Diego, CA 92115; 619-462-7445.

Sencore VA62, VC63 and NT64, includes all cables, in original boxes, excellent condition, \$2,995 or best offer. *Wayne's TV*, 312 Second Ave., P.O. Box 81, Low Moor, IA 52575; 319-522-2456 after 4 p.m.

Sams Photofacts from #1 to #1000 complete, best offer; 1,000 receiving tubes. Send SASE for list. *Brian Wotowicz*, RD 2, Thornhill Drive, New Castle, PA 16101; 412-652-4591.

CK 3000 Sylvania test jig; B&K 1075 analyst and A 107 CRT analyzer; Yeats TV dolly; B&K tube tester; misc. triplers, modules and condensers; manuals — RCA and Zenith; ES&T Profax from start. *Robert Rash*, Custom TV, 137 Sir Damas Drive, Riverside, CA 92507; 714-686-2019.

All car radio parts, boxed, all new, dated back to Kaison and Packerd; radios in original boxes; 12V vibroter, boxed; old Ford antennas; old car radio manuals. *Gorski TV*, 134 Voorhess Corner Road, Flemington, NJ 08822; 201-782-5468. ■

## Classified

Advertising rates in the Classified Section are \$1.65 per word, per insertion, and must be accompanied by payment to insure publication.

Each initial or abbreviation counts as a full word.

Minimum classified charge \$35.00.

For ads on which replies are sent to us for forwarding (blind ads), there is an additional charge of \$40.00 per insertion to cover department number, processing of replies, and mailing costs.

Classified columns are not open to advertising of any products regularly produced by manufacturers unless used and no longer owned by the manufacturer or distributor.

### FOR SALE

**VHS-VCR Repair Solutions Volumes I, II, III, IV.** Each contains 150 symptoms and cures, cross reference chart, free assistance. Each \$11.95, any two \$19.95, any three \$29.95, all \$39.95. *Eagle Electronics*, 52053 Locks Lane, Granger, IN 46530. 01-89-TFN

**TV/VCR TUFF TIPS** listed by mfg. & model. Over 400 tips. \$21.95. TV Tips only \$11.95, VCR Tips only \$13.95. **VCR CROSS-REFERENCE** listing for electronically similar manufacturers, RCA, GE, Sylvania, Panasonic, Quasar, Magnavox, Philco, & J.C. Penney, \$19.95. **TV/VCR FAILURE HISTORIES.** Multiple cures for most problem areas. Send \$7.95 with mfg. and model number. Money will be refunded with free sample if model is not on database. Add \$1.50 postage and handling. **TECH CURES**, 4825 Fredericksburg Road, San Antonio, Texas 78229. 12-88-TFN

**SENCORE SC-61 SCOPE**, 1 yr. old, 100MHz digital dual trace. One probe readout DC w/its. peak to peak, frequency, and Delta measurements. Eliminates graticule counting. Obsolete conventional scopes. \$1500 sacrifice, \$3000 new. Call collect 618-235-4735. 7-89-11

**TV TROUBLESHOOTING:** Over 300 problems/solutions. Nothing old listed. \$12.00, add \$1.50 shipping. Refund if not satisfied. *Jones Electronics*, Box 702, Niceville, FL 32578. 6-89-TFN

**REDUCED 75%.** Diehl Mark V scanner \$249, Diehl Mark III scanner \$99. New. 2805 University Ave., Madison, Wis. 53705, 608-238-4629, 608-233-9741. 3-89-tfn

**TV TOUGH DOGS:** 300 symptoms and cures. Send \$8.95 to DAVIS TV, 11772 Old Fashion Way, Garden Grove, CA 92640. 10-87-lfn

**PHOTOFACTS:** Folders under #1400, \$4.00. Above #1400, \$6.00. Sent same day first-class postpaid. *Loeb*, 414 Chestnut Lane, East Meadow, NY 11554. 6-89-3t

### SERVICES

**SPEAKER REPAIR.** 4"-18" Speakers reconed. Cross-over parts. *Orban Audio*, 119 7th St. NW, North Canton, Ohio 44720, (216) 497-9932 6pm-9pm EST. 4-89-tfn

### HELP WANTED

**SOLID OPPORTUNITY** in Northern California. Audio-Video Technicians and Managers. We are Northern California's leading retailer/servicer of prestigious home electronics, servicing brands like Yamaha, Luxman, Mitsubishi, Denon, Hitachi, and many more, and we're looking for some **good technicians and service managers** to continue to grow with our company in this beautiful wine-country area. Current openings in Santa Rosa and Bay Area. Call Pete Coleman at (707)546-2736, or send resume to Technical Department, 2340 Coddington Center, Santa Rosa, CA 95401. M & W ELECTRONICS, INC.

### BUSINESS OPPORTUNITIES

**BE YOUR OWN BOSS**—Audio/Video/TVRO sales and service. Perfect small business for 1-2 man operation. Profitable Colorado business. Low overhead, owner can finance. 303-867-3554. 6-89-2t

**AUDIO-VIDEO SERVICE.** Big-Ten university sports/culture, small town atmosphere. \$60K and growing. *Hessian Electronics*, 401 S. Gilbert Street, Iowa City, Iowa 52240. (319) 351-5290. 7-89-1t

**A SMALL TOWN—BUSY SHOP**, equipment & inventory, owner retiring, price negotiable. Box 488, Salmon, Id. 83467. 208-756-2916. 7-89-1t

**VCR SERVICE COMPANY** in beautiful Monterey, CA. \$40,000-\$50,000 yearly sales. \$25,000 in parts, equipment, furniture and fixtures. Using only 400 square feet of 2,200 square feet. Busy drive-by corner building. Lease/rent—Only \$675/mo. for entire facility. Lots of room to expand at no extra rent cost. Illness forces give away sale price of only \$39,500. Hurry! Won't last. 408-649-6036. 7-89-3t

**TV SALES & SERVICE:** Beautiful Northern Arizona. Retiring due to health. Loaded with lup to date test equip. Huge inventory. Sams photofacts from year one. Also Sharp, Fisher, JVC, Sansui, Sanyo, Samsung, RCA, GE, etc. Same location 26 years. Priced to sell, \$45,000. For more information 602/635-4352. 7-89-2t

**ELECTRONICS BUSINESS:** very diverse, factory sys contracts, installations for major dealers, growing security dept., all equipment & truck included, \$55,000. Northern N.J. 201-575-6217. 6-89-3t

## WE'RE THE ONE . . .

- With over 12,000 Electronic Products
- With LOW Prices & Volume Discounts
- With the PRB LINE of Replacement Belts & Tires

Call Toll FREE

1-800-558-9572 in Wis. 1-800-242-9553  
24 HOUR ORDERING: FAX: 414-473-4727

"First in Quality And Service"

# PRIME

**ELECTRONICS CO.**

P.O. Box 28 • Whitewater, Wisconsin 53190

Circle (21) on Reply Card

## FIX VCR's

3 out of 4 VCR breakdowns are due to mechanical problems.

Do you have the tools to find these problems?



TENTEL® Does!

Call Toll Free

**(800)538-6894**

In Calif -(408) 379-1881

TENTEL

Circle (22) on Reply Card

### WHY PAY SENCORE \$1295?

TEST/CLEAN/RESTORE with a UNIVERSAL CRT ADAPTER that fits all CRT testers and quickly hooks-up to all CRT's on the market (now or in the future). Guarantees profit & total CRT servicing. Used by TV Repair, US Govt., Airlines, Computer Serv., Dept. of Defense. Patented Adaptor-Sockets-CRT Reference/Setup book—Only \$59.95 plus \$2.50 postage & handling. Our 6th year. Over 15,000 sold. Chargecards/Checks/COD. Money Back Guarantee.

FREE CALL 1-800-331-9658

DANDY MFG. CO./RANDALL ELECTRONICS  
(918) 682-4286, 2323 Gibson St., Muskogee, OK 74403

Circle (23) on Reply Card

**"Tech's Guide To Pricing"**  
updated new 5th edition, a framework for setting rates that apply to Hi-Tech products, a formula that guarantees SUCCESS!  
Call Toll Free for details 8/5  
**1-800-228-4338** CST

Circle (20) on Reply Card

## REPRINTS

Interested in ordering article reprints out of this or another issue? \* Reprints can be excellent learning tools for your technical staff and great marketing tools for your sales staff. Call or write Kelly Hawthorne at Intertec Publishing Corp., P.O. Box 12901, Overland Park, KS 66212; (913) 888-4664.

\* Minimum order 500 copies.

## Ad Index/Hotline

Company	Page Number	Reader Service Number	Advertiser Hotline
Automated Production Equipment Corp. . . . .	51	16	516/654-1197
Chicago Case Co. . . . .	23	9	312/927-1600
Consolidated Electronics, Inc. . . . .	55	18	800/543-3568
Dandy Mfg. Co. . . . .	60	23	800/331-9658
ETA . . . . .	55		
Falcon Safety Products, Inc. . . . .	11	6	201/707-4900
Fluke, John Mfg. Co., Inc. . . . .	5	4	800/227-3800
Hitachi Sales Corp. of America . . . . .	41	11	516/921-7200
HMC-HUB Materials Company . . . . .	45	12	
Iscet . . . . .	57		
Leader Instrument Corp. . . . .	3	2,3	800/645-5104
Nesda . . . . .	45, 53		
Nutronix, Inc. . . . .	49	14	313/939-4710
Parts Express Int'l., Inc. . . . .	21	8	513/222-0173
Prime Electronics . . . . .	60	21	414/473-4727
PTS Corp. . . . .	37	10	800/333-PTS1
Sencore, Inc. . . . .	IFC	1	800/843-3338
Simpson Electric Co. . . . .	15	7	312/697-2260
Sperry Tech, Inc. . . . .	60	20	800/228-4338
Techni-Tool . . . . .	51	15	215/825-4990
Tektronix, Inc. . . . .	8A-8B,9		800/835-9433
Tentel . . . . .	60	22	800/538-6894
Tool Kit Specialists, Inc. . . . .	49	13	800/621-0854
Vaco Products . . . . .	53	17	
Viejo Publications . . . . .	53	17	800/537-0589
Zenith . . . . .	BAC		

### ADVERTISING SALES OFFICES

## ELECTRONIC

*Servicing & Technology*

#### KANSAS CITY, MISSOURI

Greg Garrison, Sales Manager

P.O. Box 12901

Overland Park, KS 66212

Phone: (913) 888-4664

Fax: (913) 541-6697

Telex: 42-4156 INTERTEC OLPK

#### OXFORD, ENGLAND

Nicholas McGeachin

Roseleigh House, New Street

Deddington, Oxford OX5 4SP

Phone: (0869) 38794

Telefax: (0869) 38040

Telex: 837469 BES G

#### TOKYO, JAPAN

Mashy Yoshikawa

Orient Echo, Inc.

1101 Grand Maison

Shimomiyabi-Cho, 2-18

Shinjuku-ku, Tokyo 162, Japan

Tel: 03-235-5961

Telex: J-33376 MYORIENT

#### FREWVILLE, SOUTH AUSTRALIA

John Williamson

Hastwell, Williamson, Rep. Pty. Ltd.

109 Conyngham Street

Frewville 5063

South Australia

Phone: (08) 79 9522

Fax: 08 79 9735

Telex: AA87113 HANDM

# You told us what you wanted ... and we listened to you!

Over the past year you've given us your suggestions through letters, phone calls and by answering our research questionnaires. And here's what you said and what we've done for you.

You told us to publish:

- More VCR servicing articles.  
So, now ES&T gives you *Video Corner*—VCR servicing how-to information every month.
- More computer servicing articles.  
So, now ES&T gives you *Computer Corner* computer servicing information every month.
- More audio servicing articles.  
So, now ES&T gives you *Audio Corner*—how-to servicing tips every month on repairing CD players and other audio equipment.

Plus, you said to publish:

- More *Symcures*.  
So, back by popular demand, you'll find *Symcures* in ES&T every month—providing you the symptoms and cures compiled from field reports of today's most recurring equipment troubles.

And, you said to give you more information on:

- Servicing automotive electronics.
- Locating replacement parts.
- Finding servicing documentation.

Again, we've listened to you. And, ES&T will publish more of what you want and need to read about during the next few months and throughout all of 1989.

That's why now, more than ever, you can't afford to miss your next issue of *Electronic Servicing & Technology* magazine.

So, renew your subscription today. Don't delay. Use your handy subscription renewal form on page 25 in this issue. It's postage-paid for you to return to ES&T, so it won't cost you a cent.

Renew your subscription now. Because, now more than ever, ES&T is delivering what you want and need to read to succeed in your business.

The how-to magazine of electronics...

**ELECTRONIC**  
Servicing & Technology

**For your own reputation  
and in your customers' best interest  
always insist on**

**Genuine Zenith**  
**Remanufactured Replacement Parts**  
**Reconditioned and Serviced for Reliability**  
**by Zenith People**  
**as Knowledgeable and Dedicated as**  
**Those Who Made the Originals!**

One of the easiest, fastest, and surest ways for you to preserve the pedigree and maintain the quality of the Zenith products you service is with genuine Zenith replacement parts.

And at no time is this more critical than when you replace the more sophisticated components like modules, tuners, channel selectors and sub-assemblies.

Your participating Zenith parts distributor will supply you with a replacement remanufactured, reconditioned and serviced for reliability by Zenith people as dedicated and knowledgeable as those who made the original.

Equally important, the replacement module or sub-assembly you receive in exchange from your Zenith parts distributor

will most likely incorporate any Zenith factory-made modifications in effect at the time of remanufacture.

And nowhere else but in a participating Zenith parts distributor's Exchange Program can you get assurance that a replacement incorporates Zenith factory up-dates!

To learn the location of the Zenith R&R Exchange Counter in your area, write on your company letterhead and we will help you locate one that's nearby.

Risking an exchange for a Zenith replacement anywhere else doesn't make sense. Not when factory-fresh replacement modules and sub-assemblies are so readily available thru a Zenith parts distributor's Exchange Program! Write now!



The quality goes in before the name goes on.®